

CHAMPION

Parts Manual

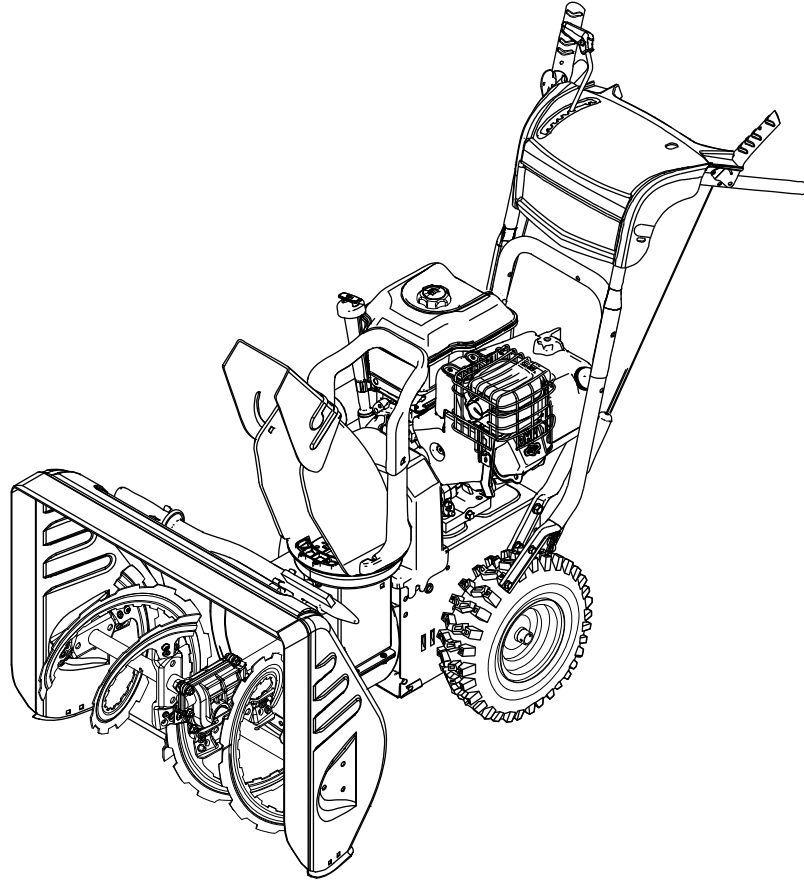

ST661BS

24" Dual Stage Snowthrower

Models

Mfg. No.	Description
1696410-00	ST661BS, Champion 7.5TP 24" Dual Stage Snowthrower (CE) (2013)

Manual Part No. 1757471

Revision -

Rev. Date: 5/28/2013

PRODUCT COMPONENTS	PAGES
Handles & Controls Group	4
Engine Group	8
Auger Housing Group	10
Auger Drive Group	12
Traction Drive Group	14
Wheels & Tires Group	16
Decals Group	18
Gear Case Assembly	20
Discharge Chute Group - Manual	22
Torque Specification Chart	Inside Back Cover

Handles & Controls Group

NOTE: Unless noted otherwise,
use the standard hardware torque
specification chart.

2991249

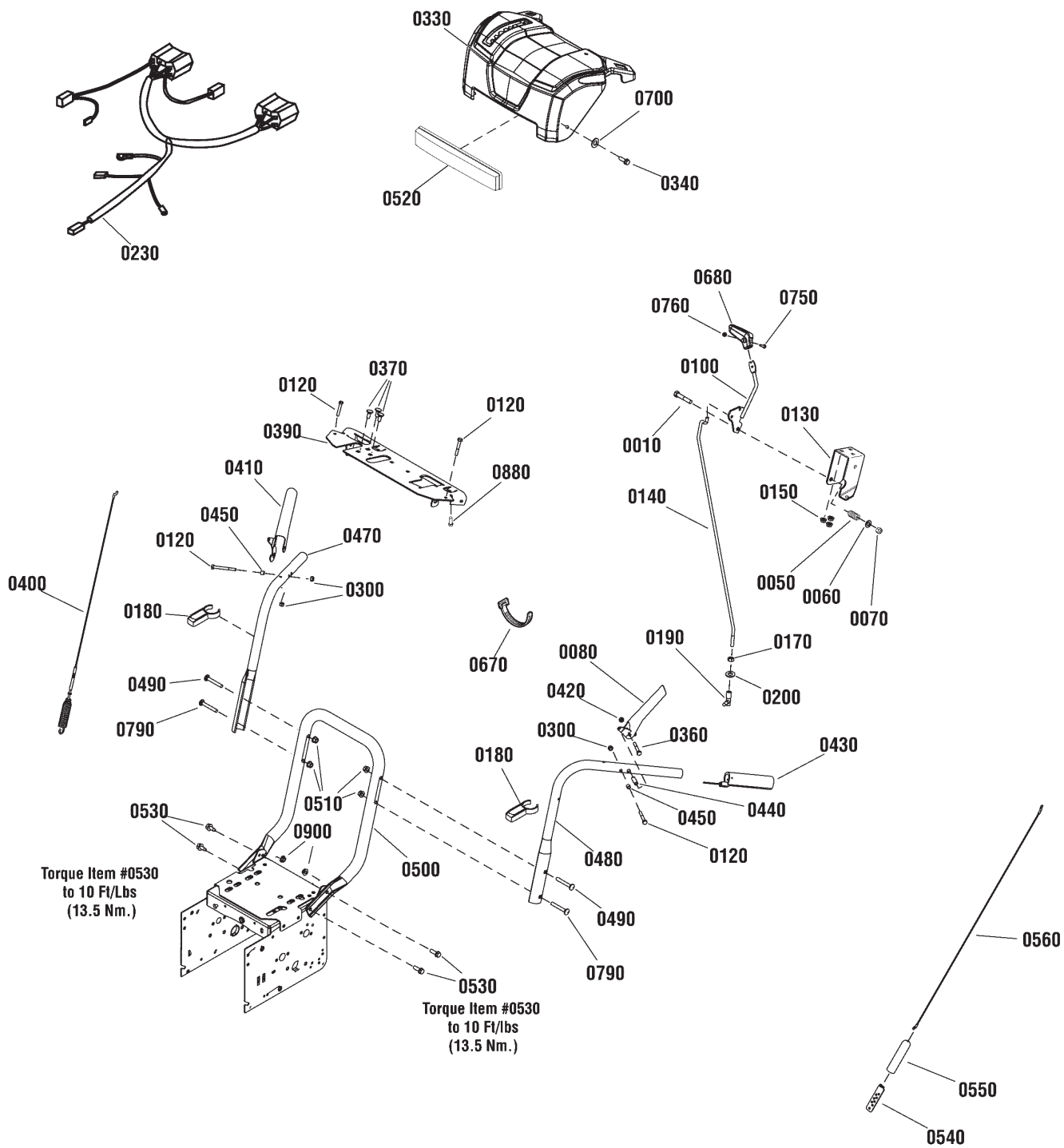

The above parts group applies to the following Mfg. Nos.:
1696410-00 - ST661BS

Handles & Controls Group

REF NO	PART NO.	QTY.	DESCRIPTION
0010	703589	1	CAPSCREW, Hex Head, 3/8-16 x 2, GR5
0050	50786MA	1	SPRING, 3/4"
0060	71072MA	1	WASHER, 3/8
0070	1919439SM	1	NUT, Hex Lock, ESNA LIGHT, 3/8-16
0080	1739782AYP	1	LEVER, Clutch, LH
0100	703047	1	SPEED LEVER
0120	7091003YP	4	CAPSCREW, Hex Head, 1/4-20 x 1-3/4, GR5
0130	1737684YP	1	BRACKET, Controls
0140	1751543YP	1	ROD, 25"
0150	690272MA	3	NUT, Hex Flange, Whiz Lock, 5/16-18
0170	703331	2	NUT, Hex, 5/16-24
0180	1739510YP	2	BRACKET, Lower Mounting
0190	703224	1	BALLJOINT
0200	1917356SM	1	LOCKWASHER, Spring, 5/16
0300	1920397SM	4	NUT, Hex Lock, ESNA LIGHT, 1/4-20
0330	1757473YP	1	COVER ASSEMBLY, Panel
0340	703062	2	SCREW, Hex Washer Head, Plastite, 10-14 x 5/8
0360	1753529YP	2	BOLT, Shoulder, 1/4 x 1-1/4
0370	703185	3	BOLT, Carriage, 5/16-18 x 3/4, G5
0390	1739500AYP	1	SUPPORT, Dash
0400	703221	1	CABLE, Auger Drive
0410	1739783AYP	1	LEVER, Clutch, RH
0420	1933896SM	2	NUT, Hex Lock, Nylon Insert, 10-24
0430	1726317SM	2	GRIP
0440	703223	2	SPACER, Stepped
0450	703045	2	SPACER, 1/4 ID x 3/8 OD x 5/16"
0470	1734587ASM	1	HANDLE, Upper, RH
0480	1734586ASM	1	HANDLE, Upper, LH
0490	1960273SM	2	BOLT, Carriage, Short Neck, 5/16-18 x 2-1/4, GR5
0500	1737274AYP	1	HANDLE, Lower
0510	703115	4	NUT, Hex Flange, ESNA, 5/16-18
0520	1754423YP	1	INSERT
0530	703225	4	BOLT, Carriage, 5/16-18 x 3/4, GR5
0540	313441MA	1	BRACKET, Cable Adjusting
0550	308146MA	1	BOOT, Spring End Cover

Footnotes

The above parts group applies to the following Mfg. Nos.:

1696410-00 - ST661BS

Handles & Controls Group

NOTE: Unless noted otherwise,
use the standard hardware torque
specification chart.

2991249

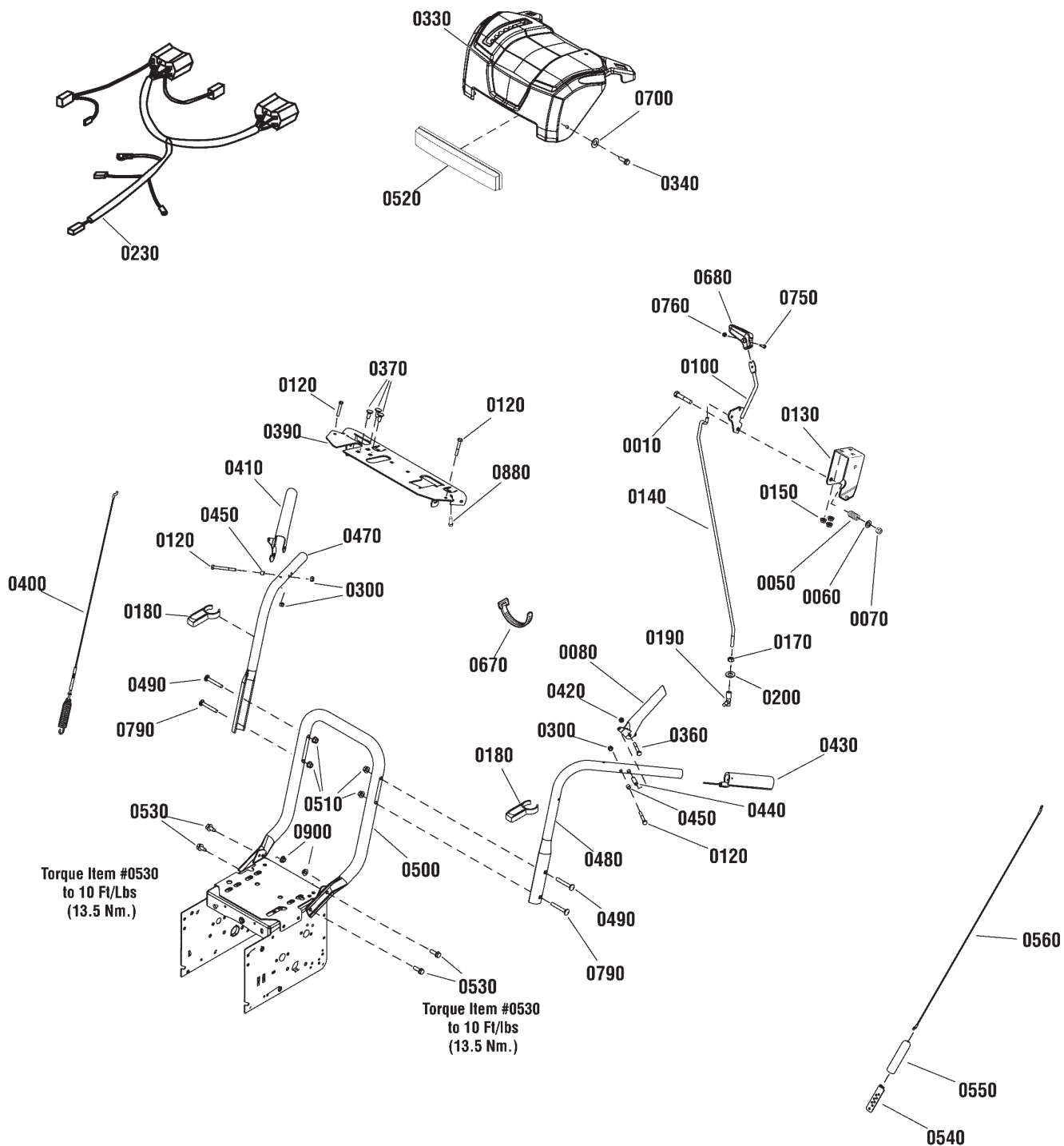

The above parts group applies to the following Mfg. Nos.:
1696410-00 - ST661BS

Handles & Controls Group

REF NO	PART NO.	QTY.	DESCRIPTION
0560	1501124MA	1	CABLE, Front Drive
0670	703586	4	TIE, Self Lock
0680	1733192SM	1	KNOB, Slot Speed
0700	703332	2	WASHER, 1/4
0750	703944	1	SCREW, Round Head Phillips, #10-16 x 3/4
0760	7091290SM	1	NUT, Hex Lock, Nylon, #10C
0790	703175	2	BOLT, Carriage, Short Neck, 5/16-18 x 1-3/4, GR5
0880	7091081SM	2	SCREW, Hex Washer, Self Tap, 1/4-15 x 3/4
0900	1960684SM	2	NUT, Hex Flange, ESNA, 5/16-18

Footnotes

The above parts group applies to the following Mfg. Nos.:

1696410-00 - ST661BS

Engine Group

NOTE: Unless noted otherwise, use the standard hardware torque specification chart.

2990516_0662

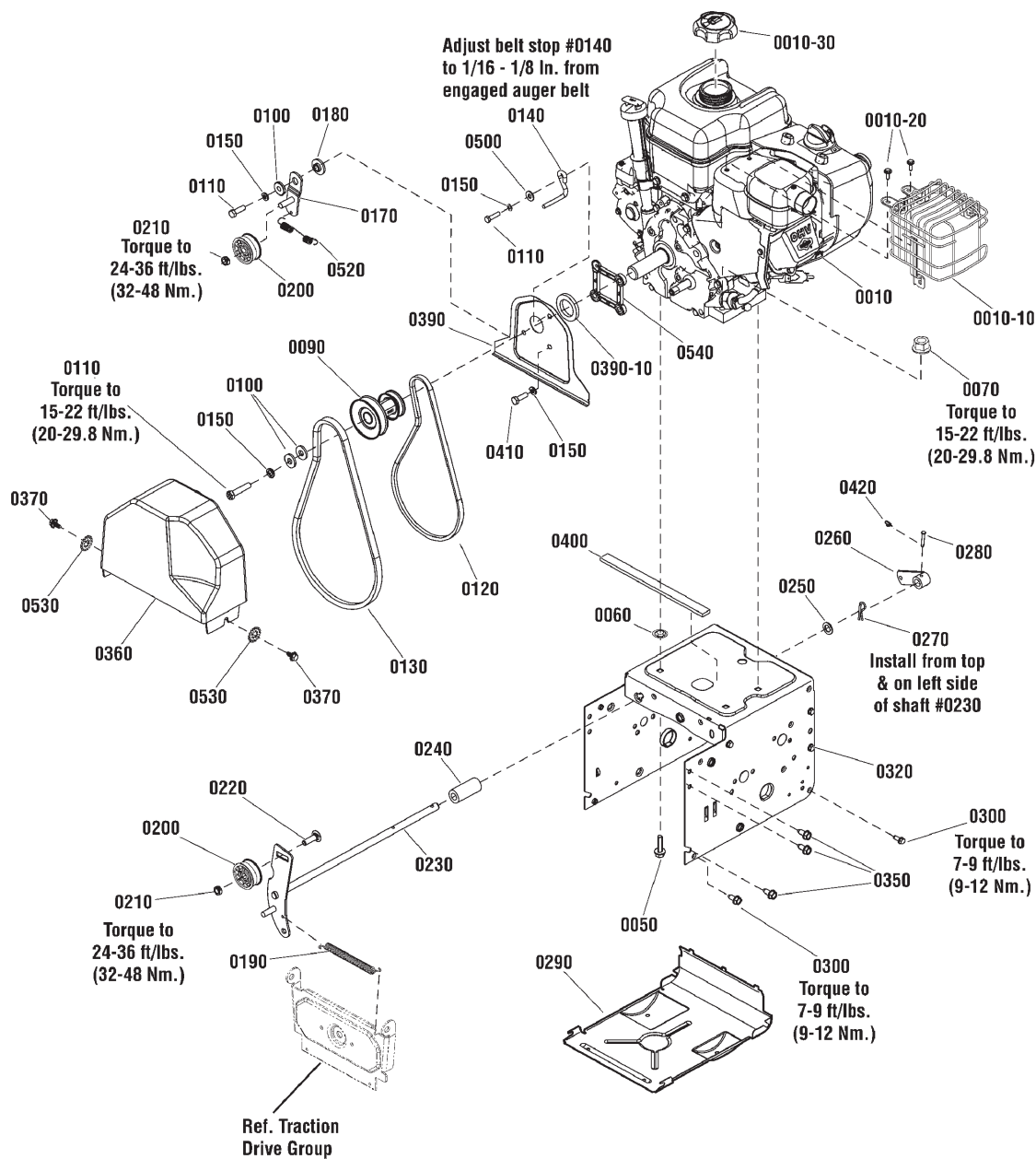

The above parts group applies to the following Mfg. Nos.:

1696410-00 - ST661BS

Engine Group

REF NO	PART NO.	QTY.	DESCRIPTION
0010	10D132-0110-F8	1	* ENGINE, 163CC Briggs & Stratton Snow Series (Engine Model: 10D132-0110-F8)
0010-10	591619	1	GUARD, Muffler (Use on 163CC Engine)
0010-20	590638	3	SCREW, Muffler Guard (Use on 163CC Engine)
0010-30	794641	1	CAP, Fuel Tank (Use on 163CC Engine)
0050	703296	4	BOLT, Carriage, 5/16-18 x 1-1/2, G5
0060	028X76MA	4	NUT, Push, 1/4
0070	690272MA	4	NUT, Flange, 5/16-18
0090	1501109MA	1	PULLEY, Engine
0100	703298	3	WASHER, Flat, 5/16
0110	703299	3	CAPSCREW, Hex Head, 5/16-24 x 1-1/4, G5
0120	1733324SM	1	V-BELT, 3L 33.03
0130	1751417YP	1	BELT, Auger
0140	1739070YP	1	BELT GUIDE
0150	703116	4	LOCKWASHER, Spring, 5/16
0170	1501112YZMA	1	BRACKET, Idler
0180	1501065MA	1	BUSHING, Idler Bracket
0190	165X159MA	1	SPRING, Extension, Auger
0200	1502120MA	2	IDLER, Plastic Ball Bearing
0210	1960251SM	2	NUT, Center Lock, 3/8-16
0220	1960032SM	1	SCREW, Hex Head, 3/8-16 x 1-1/4
0230	1752397YP	1	AUGER IDLER
0240	1501200MA	1	SPACER, Plastic, 1/2 ID x 1 OD, 1-3/4
0250	703128	1	WASHER, 1/2
0270	403162MA	1	PIN, Hair
0290	1753969BMYP	1	COVER, Bottom
0300	703054	4	SCREW, Hex Washer Head, Taptite, 1/4-20 x 5/8
0320	1754891ZYP	1	FRAME BOX
0350	703228	6	SCREW, Thread Rolling, 5/16-18 x 3/4
0360	1753893YP	1	COVER, Belt
0370	1751355YP	2	SCREW, Hex Washer Head, Taptite, 1/4-20 x 3/4
0390	1733868BMYP	1	PLATE, Seal
0390-10	1754847YP	1	SEAL, Shaft, 3/8" Thick (Use on 163CC Engine)
0400	1750172YP	1	STRIP, Seal
0410	910828MA	2	BOLT, Hex, 5/16-24 x 1
0500	1924874SM	1	WASHER, Flat, 5/16
0520	165X164MA	1	SPRING, Extension, Idler
0530	7091890SM	2	WASHER, Internal Lock, 1/4
0540	1754362YP	1	SPACER BLOCK (Use on 163CC Engine)

Footnotes

Note* To verify your specific engine model, please reference the ID Tag located on your engine. See your local Briggs & Stratton distributor for parts and service.

The above parts group applies to the following Mfg. Nos.:

1696410-00 - ST661BS

Auger Housing Group

NOTE: Unless noted otherwise,
use the standard hardware torque
specification chart.

2989964

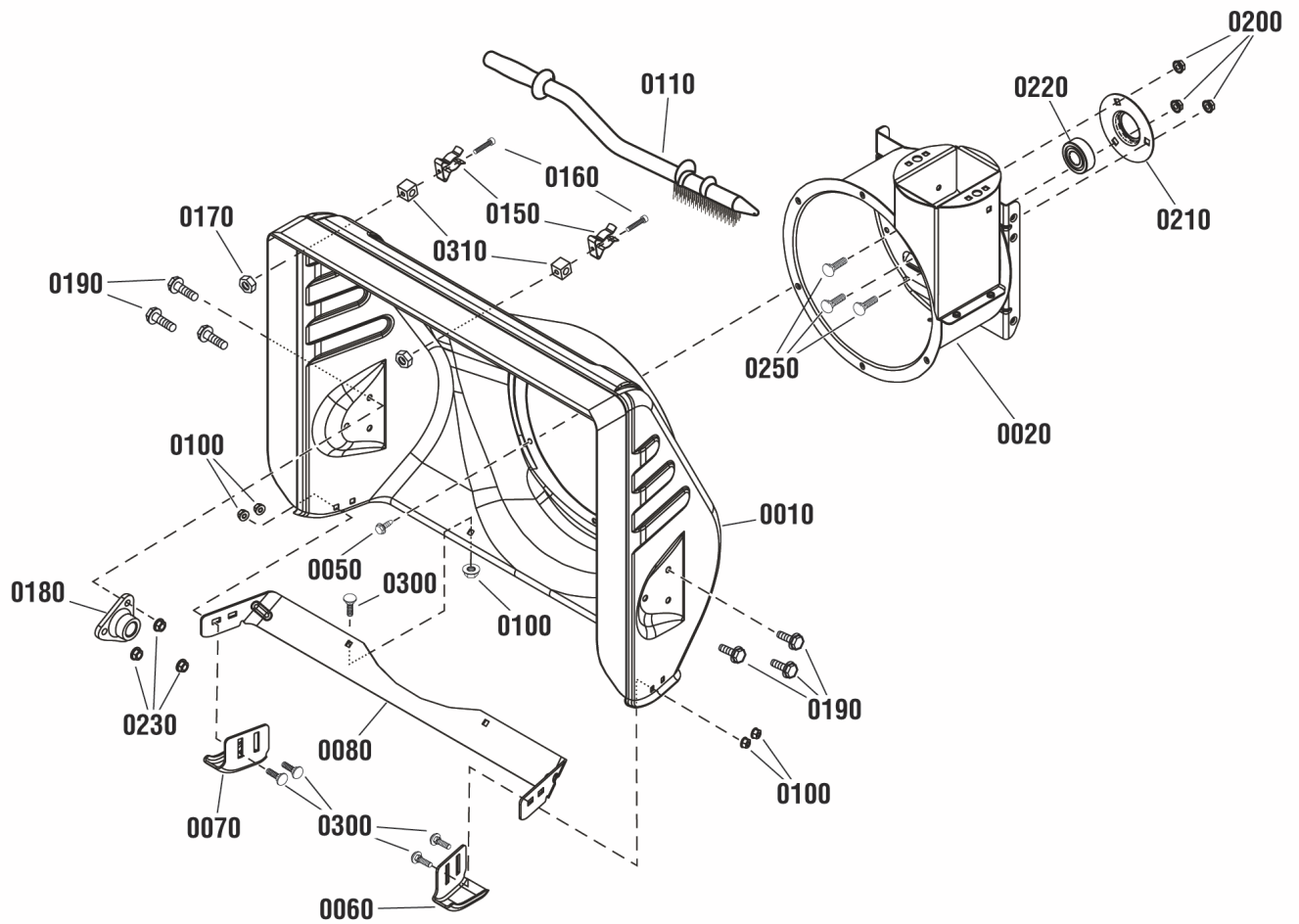

The above parts group applies to the following Mfg. Nos.:
1696410-00 - ST661BS

Auger Housing Group

REF NO	PART NO.	QTY.	DESCRIPTION
0010	1687751YP	1	AUGER HOUSING KIT, Stamped, VL
0020	1755361ZYP	1	HOUSING ASSEMBLY, IMPELLER, 10"
0050	703583	14	SCREW, Hex Washer Head, Taptite, 1/4-20 x 3/8
0060	1751407AYP	1	SKID SHOE, LH
0070	1751406AYP	1	SKID SHOE, RH
0080	1751418AYP	1	SCRAPER BAR
0100	5025391SM	6	NUT, Hex Nylock Flange, 1/4-20
0110	1736094YP	1	STICK, Cleanout Brush, 22-1/2
0150	1736620YP	2	CLAMP, Spring, Snow Brush
0160	1750897YP	2	BOLT, Truss Head, 10-24 x 1-1/4
0170	15X146MA	2	NUT, Nylock, 10 x 24
0180	9517MA	2	BEARING, Auger
0190	9357MA	6	CAPSCREW, Tapping, 5/16-18 x 3/4
0200	1931277SM	3	NUT, Hex Flange, Serrated Lock, 5/16-18
0210	1665982SM	1	RETAINER, Bearing
0220	2108202SM	1	BEARING, Ball, 3/4 ID x 1-3/4 OD x 5/8"
0230	711862MA	6	NUT, Hex Flange, Top Lock, 5/16-18
0250	703185	3	BOLT, Carriage, Short Neck, 5/16-18 x 3/4
0300	1931317SM	6	BOLT, Carriage, 1/4-20 x 3/4 G5
0310	578063MA	2	BLOCK, Universal Pivot

Footnotes

The above parts group applies to the following Mfg. Nos.:

1696410-00 - ST661BS

Auger Drive Group

NOTE: Unless noted otherwise,
use the standard hardware torque
specification chart.

2990523

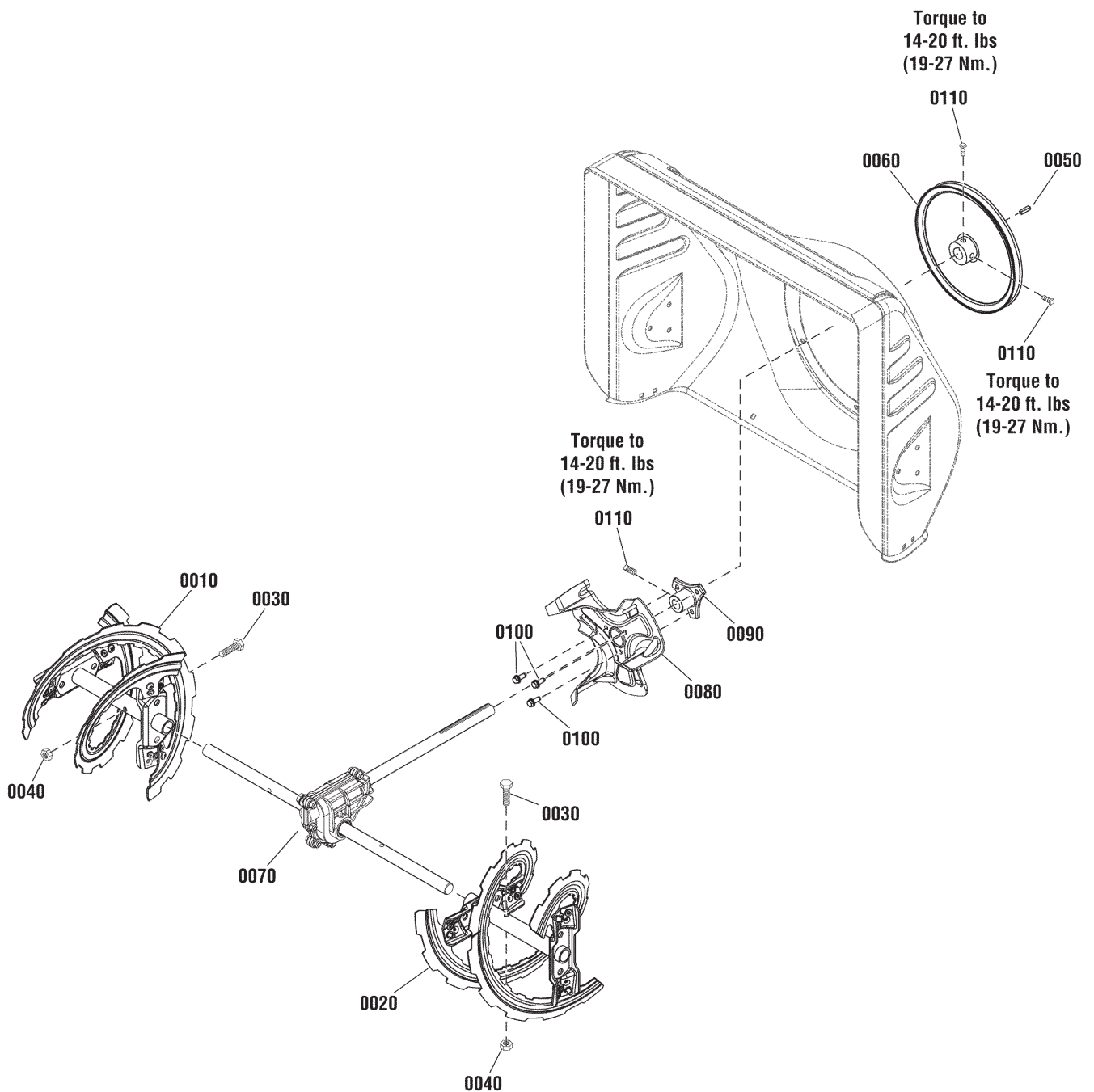

The above parts group applies to the following Mfg. Nos.:

1696410-00 - ST661BS

Auger Drive Group

REF NO	PART NO.	QTY.	DESCRIPTION
0010	1752081BCYP	1	AUGER ASSEMBLY, RH
0020	1752067BCYP	1	AUGER ASSEMBLY, LH
0030	703057	2	CAPSCREW, Hex Head, 1/4-20 x 1-3/4, G2
0040	703251	2	NUT, Hex Centerlock, 1/4-20
0050	2001022MA	1	KEY, Square, 3/16 x 3/4
0060	1752220YP	1	AUGER PULLEY
0070	1753221YP	1	GEAR CASE ASSEMBLY
0080	1751348AYP	1	IMPELLER, 10"
0090	1739073YP	1	HUB, Impeller
0100	1924856SM	3	SCREW, Hex Washer Head Taptite, 5/16-18 x 1/2
0110	1930540SM	3	SET SCREW, Square Head, 5/16-18 x 5/8, G8

Footnotes

The above parts group applies to the following Mfg. Nos.:

1696410-00 - ST661BS

Traction Drive Group

NOTE: Unless noted otherwise,
use the standard hardware torque
specification chart.

2990003

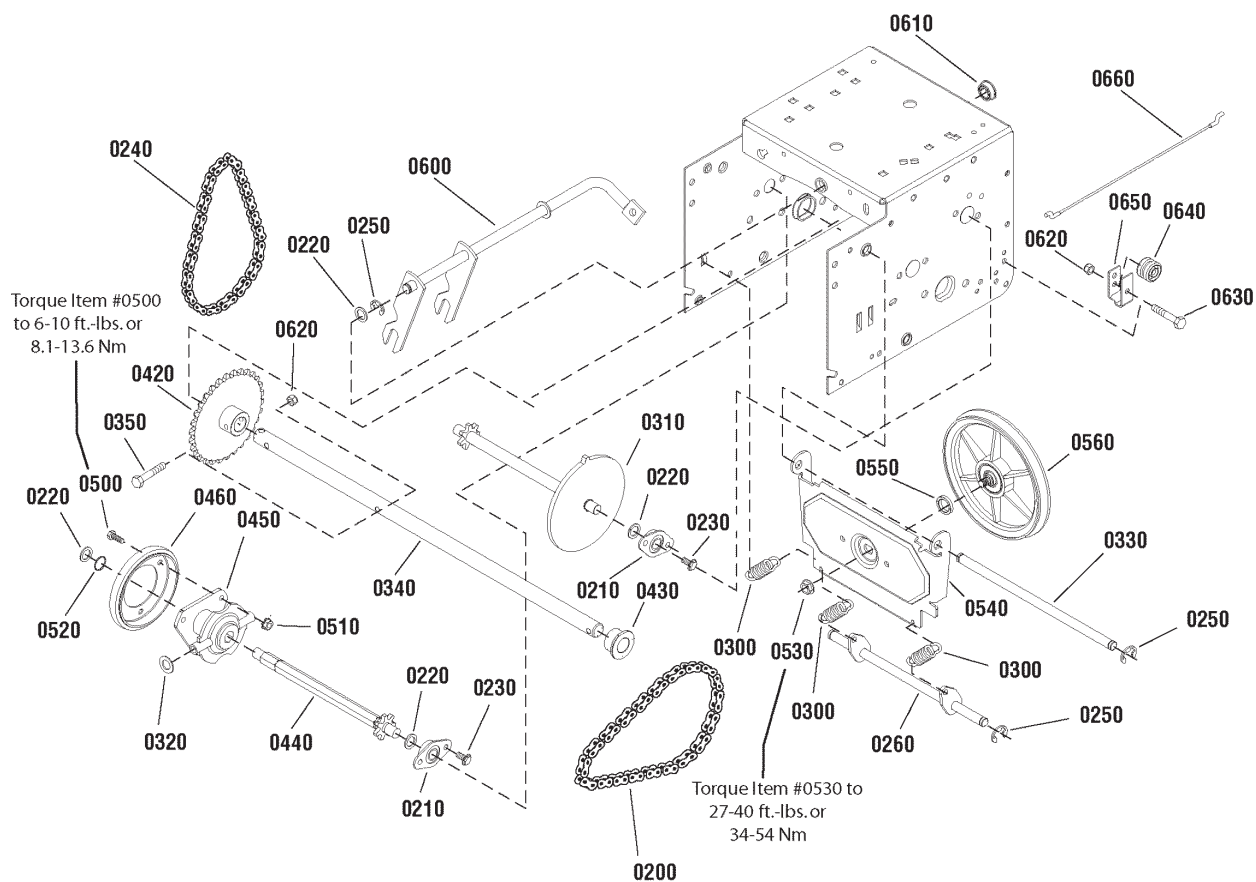

The above parts group applies to the following Mfg. Nos.:
1696410-00 - ST661BS

Traction Drive Group

REF NO	PART NO.	QTY.	DESCRIPTION
0200	579851MA	1	CHAIN, Roller, 420 x 19"
0210	334163MA	4	RETAINER & BUSHING ASSEMBLY
0220	579858MA	5	WASHER, Flat, 1/2
0230	1924856SM	8	SCREW, Hex Washer Head, Taptite, 5/16-18 x 1/2
0240	579868MA	1	CHAIN, Roller, 420 x 18"
0250	11X30MA	5	RETAINER, Ring, 7/16
0260	1502105YZMA	1	SPRING LINK
0300	1736469YP	3	SPRING, Extension
0310	1501090MA	1	SPROCKET, Set
0320	1960027SM	2	WASHER, 1/2
0330	1501092YZMA	1	AXLE, Swing Plate, 10-1/2"
0340	1501562MA	1	AXLE, 21-3/8"
0350	01X193MA	1	BOLT, Hex Head, 1/4-20 x 1-3/4, G8
0420	1501089MA	1	AXLE SPROCKET, 30T
0430	1501114MA	2	BEARING, Axle, D-Hole
0440	1501100MA	1	SHAFT, Hex
0450	1739282YP	1	BEARING TRUNNION ASSEMBLY
0460	1501435MA	1	WHEEL, Friction
0500	1921959SM	3	CAPSCREW, Hex Head, 1/4-20 x 5/8, G5
0510	1928372SM	3	NUT, Hex KEPS, 1/4-20
0520	1733326SM	1	RING, Retaining, External Tooth, # 63
0530	15X114MA	1	NUT, Flange Lock, 3/8-24
0540	1501057YZMA	1	PLATE, Swinging
0550	1501158MA	1	SPACER, Friction Pulley
0560	1501115MA	1	FRICTION PULLEY ASSEMBLY
0600	1501110YZMA	1	SPEED SELECTOR
0610	579944MA	1	BEARING, Flange, 1/2 ID x 7/8OD
0620	1920397SM	2	NUT, Hex Lock, ESNA Light, 1/4-20
0630	1922837SM	1	CAPSCREW, Hex Head, 1/4-20 x 1-1/2, G5
0640	579860MA	1	SPOOL CABLE, Auger Control
0650	1501059YZMA	1	BRACKET, Cable Spool
0660	1501122MA	1	CABLE, Forward Drive, Lower

Footnotes

The above parts group applies to the following Mfg. Nos.:

1696410-00 - ST661BS

Wheels & Tires Group

2991250

NOTE: Unless noted otherwise,
use the standard hardware torque
specification chart.

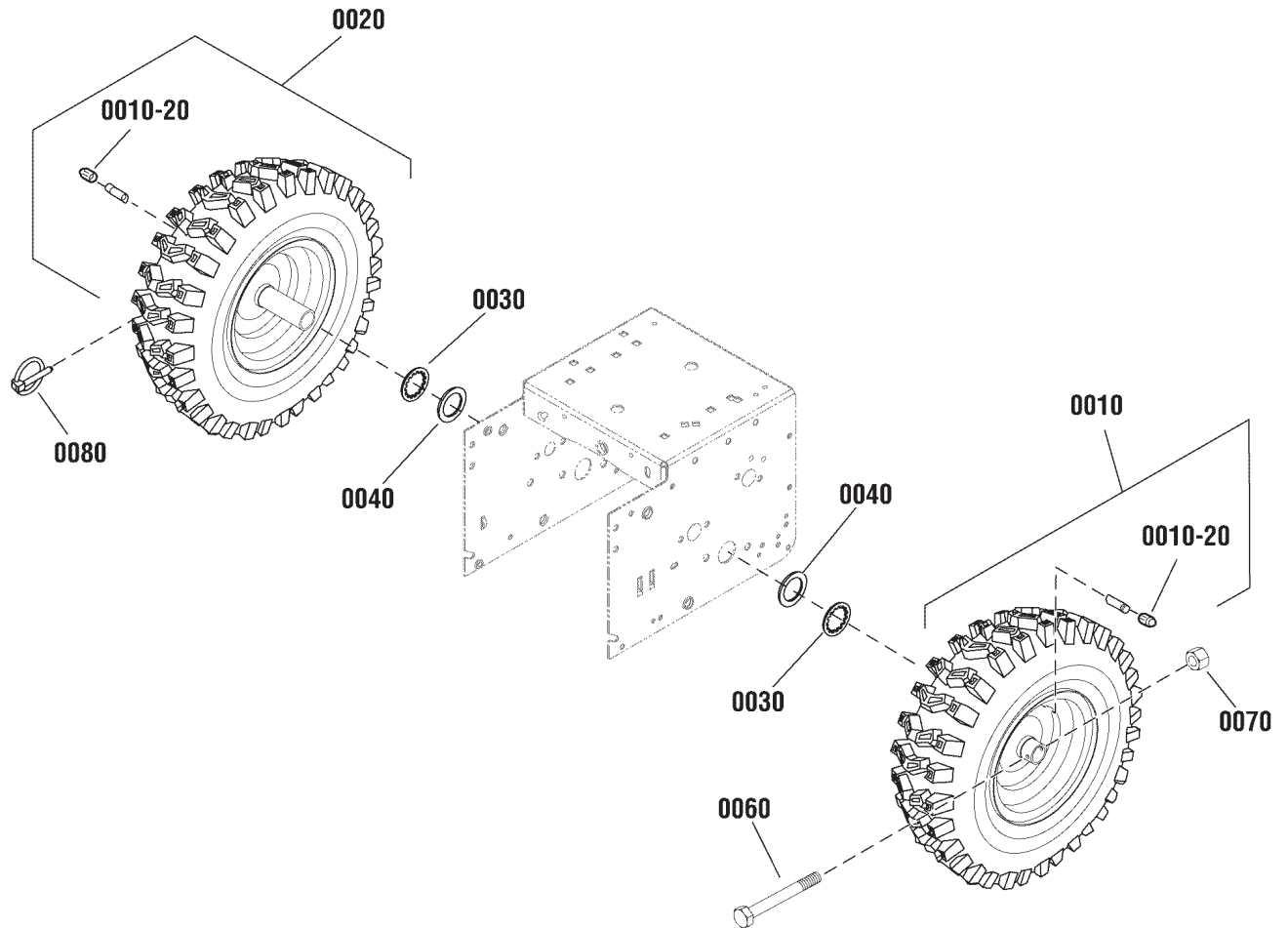

The above parts group applies to the following Mfg. Nos.:

1696410-00 - ST661BS

Wheels & Tires Group

REF NO	PART NO.	QTY.	DESCRIPTION
0010	1751285YP	1	WHEEL & TIRE ASSEMBLY, 13 x 5, LH
0020	1751286YP	1	WHEEL & TIRE ASSEMBLY, 13 x 5, RH
0010-20	2172353SM	1	VALVE STEM & CAP
0030	1657528SM	2	RING, Retaining, Self Lock, 3/4
0040	7031965YP	2	WASHER
0060	577015MA	1	BOLT, Hex, 1/4-20 x 1-3/4, G5
0070	15X145MA	1	NUT, Hex, Nylock, 1/4-20
0080	703226	1	PIN, Klik, 1/4 x 1-3/8

Footnotes

The above parts group applies to the following Mfg. Nos.:

1696410-00 - ST661BS

Decals Group

NOTE: Unless noted otherwise, use the standard hardware torque specification chart.

2991251

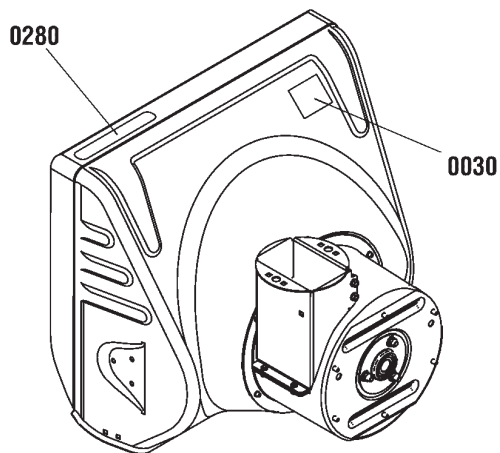
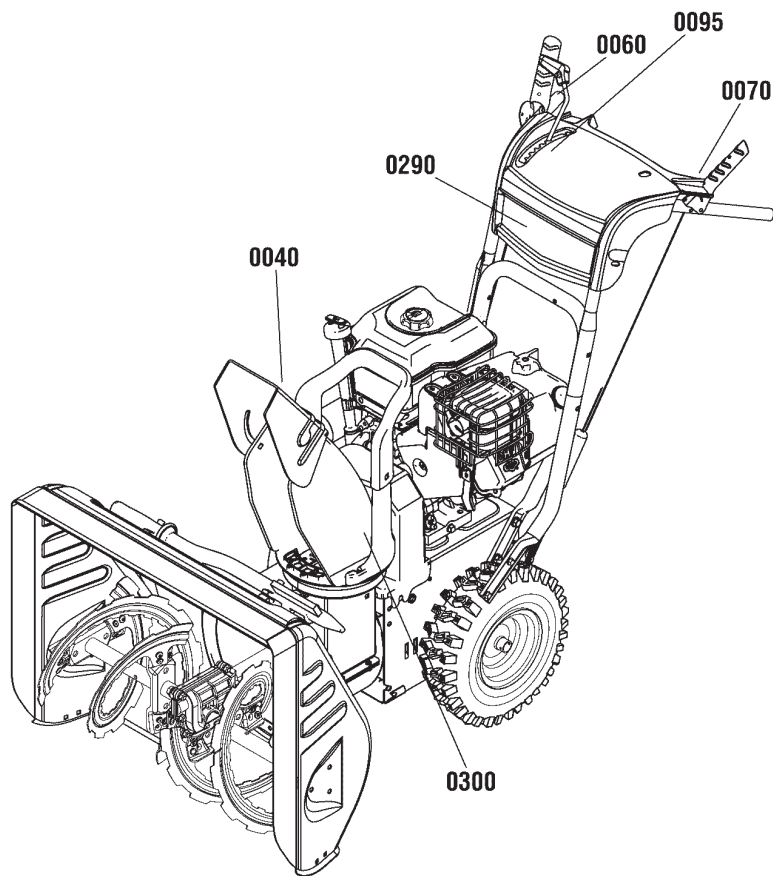

0040



0030



0060



0070



0300



0290



0280

The above parts group applies to the following Mfg. Nos.:
1696410-00 - ST661BS

Decals Group

REF NO	PART NO.	QTY.	DESCRIPTION
0030	1737867YP	1	DECAL, Safety
0040	1727207SM	1	DECAL, Chute Warning
0060	1753133YP	1	DECAL, Auger Control Symbols
0070	1753134YP	1	DECAL, Traction Control Symbols
0095	1736616YP	1	DECAL, Gear Shift
0280	1756745YP	1	DECAL, Logo, Auger Housing
0290	1757281YP	1	DECAL, Logo, Dash
0300	1757284YP	2	DECAL, Logo, Chute

Footnotes

The above parts group applies to the following Mfg. Nos.:

1696410-00 - ST661BS

Gear Case Assembly

NOTE: Unless noted otherwise,
use the standard hardware torque
specification chart.

1753221

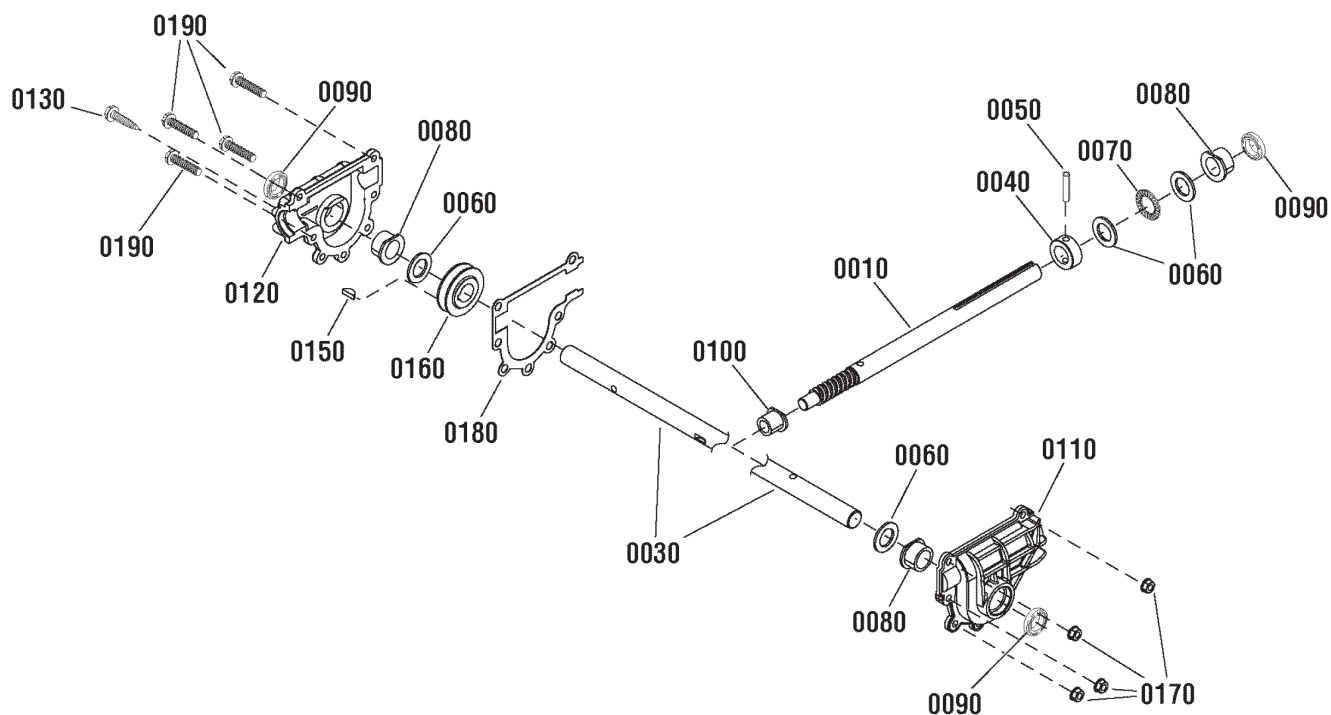

The above parts group applies to the following Mfg. Nos.:

1696410-00 - ST661BS

Gear Case Assembly

REF NO	PART NO.	QTY.	DESCRIPTION
0010	1751402YP	1	SHAFT, Impeller
0030	1751419YP	1	SHAFT, Auger
0040	580295MA	1	COLLAR, Thrust, 3/4 x 1-1/4
0050	454565MA	1	PIN, Spring, 1/4 x 1-1/4
0060	48275MA	4	WASHER, Thrust
0070	50684MA	1	BEARING, Roll Thrust, 3/4 ID x 1-1/4 OD
0080	50304MA	3	BEARING, Flange, 3/4 ID x 1 OD
0090	9566MA	3	SEAL, Oil
0100	50221MA	1	BEARING, Flange, 1/2 ID x 3/4 OD
0110	10576MA	1	CASE, Gear, LH
0120	10577MA	1	CASE, Gear, RH
0130	9344MA	1	SCREW, Hex Washer Head, Tap, 3/8-16 x 1/2
0150	431787MA	1	KEY, Woodruff
0160	1752499YP	1	GEAR, Worm
0170	15X143MA	7	NUT, Flange Lock, 1/4-20
0180	51279MA	1	GASKET
0190	710025MA	7	CAPSCREW, 1/4-20 x 3/4, GR5

Footnotes

The above parts group applies to the following Mfg. Nos.:

1696410-00 - ST661BS

Discharge Chute Group - Manual

2990644

NOTE: Unless noted otherwise,
use the standard hardware torque
specification chart.

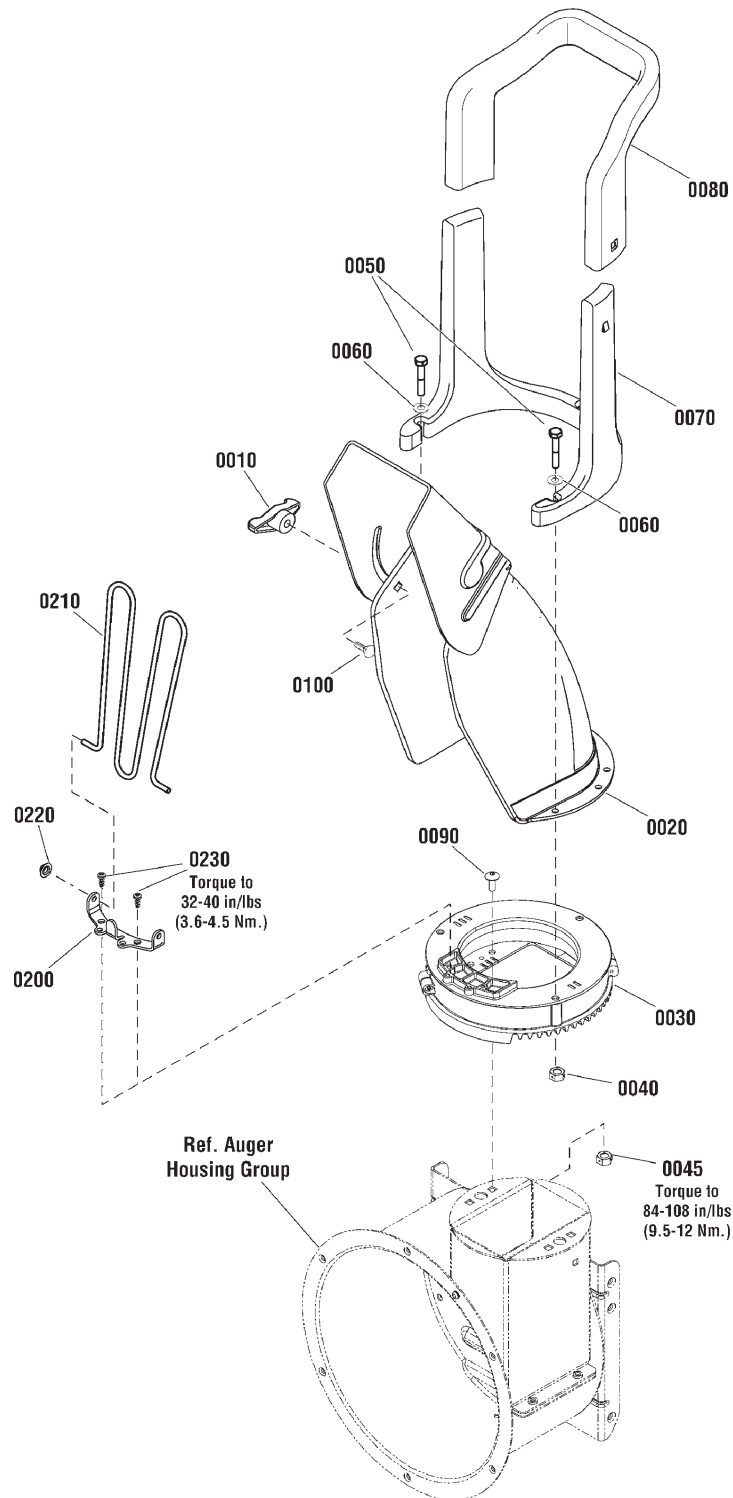

The above parts group applies to the following Mfg. Nos.:

1696410-00 - ST661BS

Discharge Chute Group - Manual

REF NO	PART NO.	QTY.	DESCRIPTION
0010	7035744YP	1	KNOB, Wing, 5/16-18
0020	1736313YP	1	CHUTE ASSEMBLY
0030	1751886YP	1	CHUTE ROTATION ASSEMBLY
0040	15X145MA	3	NUT, Hex Nylock, 1/4-20
0045	1923358SM	4	NUT, Hex Centerlock, 1/4-20
0050	51374YP	3	CAPSCREW, Hex Head, 1/4-20 x 1-1/2, G5
0060	017X37MA	3	WASHER, 1/4
0070	1752117YP	1	HANDLE, Lower
0080	1752243YP	1	HANDLE, Upper
0090	880845YP	4	SCREW, Torx, 1/4-20 x 5/8
0100	002X97MA	1	BOLT, Carriage, 5/16-18 x 1-1/2
0200	1752883YP	1	BRACKET, Chute Guard
0210	1733475SM	1	CHUTE GUARD
0220	1960140SM	2	NUT, Push, 3/16
0230	880070YP	2	SCREW, Hi-Lo, 1/2

Footnotes

The above parts group applies to the following Mfg. Nos.:

1696410-00 - ST661BS

Hardware Identification & Torque Specifications

Torque Specification Chart								
FOR STANDARD METRIC MACHINE HARDWARE (Tolerance ± 20%)								
Property Class	5.6		8.8		10.9		12.9	
	Class 5.6		Class 8.8		Class 10.9		Class 12.9	
Size Of Hardware	in/lbs		in/lbs		in/lbs		in/lbs	
	ft/lbs	Nm.	ft/lbs	Nm.	ft/lbs	Nm.	ft/lbs	Nm.
M3	5.88	.56	13.44	1.28	19.2	1.80	22.92	2.15
M4	13.44	1.28	30.72	2.90	43.44	4.10	52.56	4.95
M5	26.4	2.50	60.96	5.75	5.97	8.10	7.15	9.7
M6	44.64	4.3	7.3	9.9	10.3	14	12.1	16.5
M7	5.2	7.1	12.1	16.5	16.9	23	19.9	27
M8	7.7	10.5	17.7	24	25	34	29	40
M10	15	21	35	48	50	67	59	81
M12	26	36	61	83	86.2	117	103	140
M14	42	58	101	132	136	185	162	220
M16	64	88	147	200	210	285	250	340
M18	89	121	202	275	287	390	346	470
M20	126	171	290	390	405	550	486	660
M22	169	230	390	530	559	745	656	890
M24	217	295	497	375	708	960	840	1140
M27	320	435	733	995	1032	1400	1239	1680
M30	435	590	995	1350	1401	1900	1681	2280
M33	590	800	1349	1830	1902	2580	2278	3090
M36	759	1030	1740	2360	2441	3310	2935	3980
M39	988	1340	2249	3050	3163	4290	3798	5150

The guides and ruler furnished below are designed to help you select the appropriate hardware.

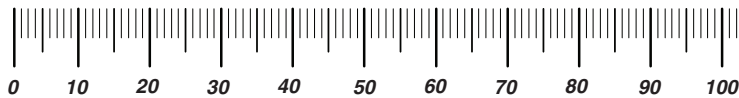

Nut, M8

Thread Diameter (mm)
Inside Diameter (in) Threads per inch

Nut, 1/2-16

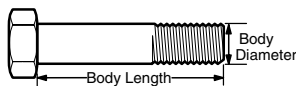

Screw, M8- 1.25 x 25

Thread Diameter (mm) Distance between threads (mm) Body Length (mm)
Body Diameter Threads per inch Body Length (in)

Screw, 1/2- 16 x 2

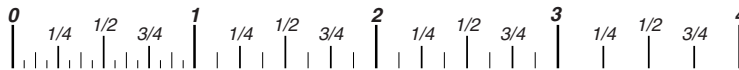

Standard Hardware Sizing

When a washer or nut is identified as **1/2"** (M8), this is the *Nominal size*, meaning the *inside diameter* is 1/2 inch (8mm metric thread diameter); if a second number is present it represents the *threads per inch* (distance between threads).

When bolt or capscrew is identified as **1/2 - 16 x 2"** (M8 - 1.25 x 50), this means the *Nominal size*, or body diameter is 1/2 inch (8mm metric thread diameter), the second number, 16, represents the *threads per inch*, (1.25 thread diameter). The final number is the body length of the bolt or screw, 2 inches (50mm).

Torque Specification Chart						
FOR STANDARD MACHINE HARDWARE (Tolerance ± 20%)						
Hardware Grade	No Marks		SAE Grade 5		SAE Grade 8	
	SAE Grade 2		SAE Grade 5		SAE Grade 8	
Size Of Hardware	in/lbs		in/lbs		in/lbs	
	ft/lbs	Nm.	ft/lbs	Nm.	ft/lbs	Nm.
8-32	19	2.1	30	3.4	41	4.6
8-36	20	2.3	31	3.5	43	4.9
10-24	27	3.1	43	4.9	60	6.8
10-32	31	3.5	49	5.5	68	7.7
1/4-20	66	7.6	8	10.9	12	16.3
1/4-28	76	8.6	10	13.6	14	19.0
5/16-18	11	15.0	17	23.1	25	34.0
5/16-24	12	16.3	19	25.8	29	34.0
3/8-16	20	27.2	30	40.8	45	61.2
3/8-24	23	31.3	35	47.6	50	68.0
7/16-14	30	40.8	50	68.0	70	95.2
7/16-20	35	47.6	55	74.8	80	108.8
1/2-13	50	68.0	75	102.0	110	149.6
1/2-20	55	74.8	90	122.4	120	163.2
9/16-12	65	88.4	110	149.6	150	204.0
9/16-18	75	102.0	120	163.2	170	231.2
5/8-11	90	122.4	150	204.0	220	299.2
5/8-18	100	136	180	244.8	240	326.4
3/4-10	160	217.6	260	353.6	386	525.0
3/4-16	180	244.8	300	408.0	420	571.2
7/8-9	140	190.4	400	544.0	600	816.0
7/8-14	155	210.8	440	598.4	660	897.6
1-8	220	299.2	580	788.8	900	1,244.0
1-12	240	326.4	640	870.4	1,000	1,360.0

NOTES

- These torque values are to be used for all hardware excluding: locknuts, self-tapping screws, thread forming screws, sheet metal screws and socket head setscrews.
- Recommended seating torque values for locknuts:
 - for prevailing torque locknuts - use 65% of grade 5 torques.
 - for flange whizlock nuts and screws - use 135% of grade 5 torques.
- Unless otherwise noted on assembly drawings, all torque values must meet this specification.

Common Hardware Types

Hex Head Capscrew



Washer

Carriage Bolt







Lockwasher



Hex Nut

Wrench & Fastener Size Guide

				
1/4" Bolt or Nut Wrench—7/16"	5/16" Bolt or Nut Wrench—1/2"	3/8" Bolt or Nut Wrench—9/16"	7/16" Bolt or Nut Wrench (Bolt)—5/8" Wrench (Nut)—11/16"	1/2" Bolt or Nut Wrench—3/4"
M6 Bolt or Nut Wrench—10mm	M8 Bolt or Nut Wrench—13mm	M10 Bolt or Nut Wrench—17mm	M12 Bolt or Nut Wrench—19mm	M14 Bolt or Nut Wrench—22mm

CHAMPION

**IT IS THE POLICY OF BRIGGS & STRATTON CORP. TO IMPROVE ITS PRODUCTS
WHENEVER IT IS POSSIBLE AND PRACTICAL TO DO SO. WE RESERVE THE RIGHT TO
MAKE CHANGES OR ADD IMPROVEMENTS AT ANY TIME WITHOUT INCURRING ANY
OBLIGATION TO MAKE SUCH CHANGES ON PRODUCTS.**

Briggs & Stratton Power Products Group

12301 W. Wirth Street
Wauwatosa, WI, 53222 USA

www.murray.com

© Copyright 2013 by Briggs & Stratton Corporation
Milwaukee, WI, USA. All rights reserved