

# SC450 B

---

Model:  
SC450 B NIL



Part List US-English

14-04-2015

# Nilfisk

[www.nilfisk.com](http://www.nilfisk.com)

# Table of Contents

SC450 B

<b>GENERAL SYSTEM</b>	<b>3</b>
<b>SOLUTION TANK</b>	<b>5</b>
<b>RECOVERY TANK</b>	<b>7</b>
<b>HANDLE BAR AND WHEELS</b>	<b>9</b>
<b>SOLUTION SYSTEM</b>	<b>11</b>
<b>SQUEEGEE SYSTEM</b>	<b>13</b>
<b>BRUSH DECK</b>	<b>15</b>
<b>CONTROL PANEL</b>	<b>17</b>
<b>ELECTRICAL COMPONENTS</b>	<b>19</b>
<b>ACCESSORIES</b>	<b>21</b>
<b>ACCESSORIES</b>	<b>23</b>
<b>WIRING DIAGRAM</b>	<b>25</b>
<b>RECOMMENDED PARTS</b>	<b>27</b>

# GENERAL SYSTEM

SC450 B

14-04-2015

Part List ID  
SC450B000

3

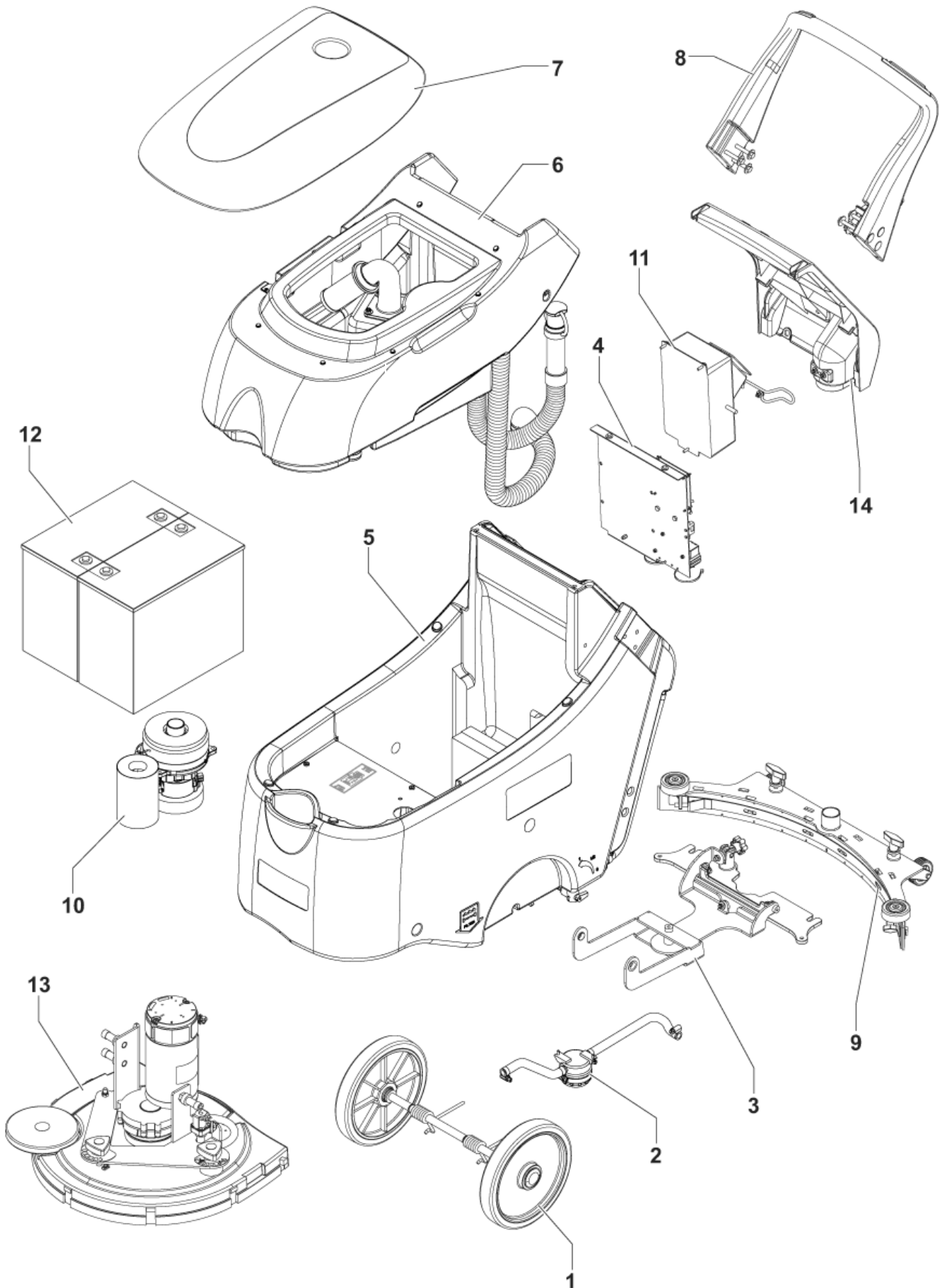

# GENERAL SYSTEM

SC450 B

14-04-2015

Part List ID  
SC450B000

4

Pos	Part no.	Qty	Description
1		1	USE LINK
2		1	USE LINK
3		1	USE LINK
4		1	USE LINK
5		1	USE LINK
6		1	USE LINK
7		1	USE LINK
8		1	USE LINK
9		1	USE LINK
10		1	USE LINK
11		1	USE LINK
12		1	USE LINK
13		1	USE LINK
14		1	USE LINK

# SOLUTION TANK

SC450 B

14-04-2015

Part List ID  
SC450B010

5

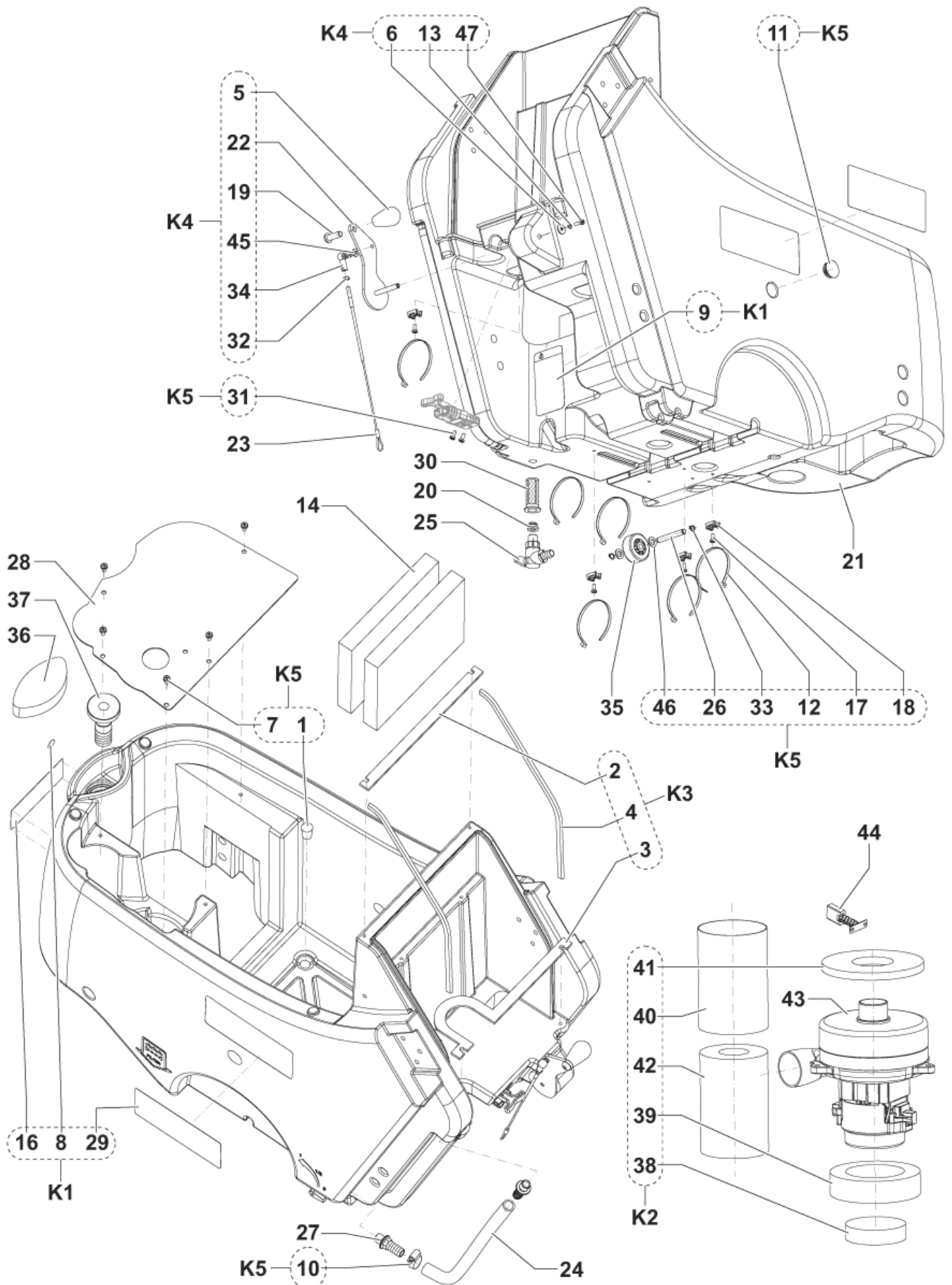

# SOLUTION TANK

SC450 B

14-04-2015

Part List ID  
SC450B010

6

Pos	Part no.	Qty	Description	
5	909 6621 000	1	KNOB	
14	146 0668 000	2	PANEL INSULATING	
20	909 5286 000	1	GASKET	
21	9099251000	1	TANK SOLUTION	
23	9099258000	1	CABLE SQUEEGEE LIFTING	
24	9099261000	1	HOSE SOLUTION	
25	9099513000	1	VALVE ELBOW 90. D.13MM	
27	9100000766	2	HOLDER RUBBER D.16 G3/8 PKD	
28	9100000168	1	PLATE VACUUM MOTOR	see TSB FC 2013-146
30	9096916000	1	FILTER SOLUTION TANK	OPTION
35	9099953000	1	WHEEL D.50	
36	9099561000	1	SPONGE WATER ENTRANCE	
37	9097290000	1	HOSE FILLING	OPTION
38	909 6672 000	1	FILTER	
43	9099922000	1	MOTOR VACUUM 330W 24V KIT	
44	909 5371 000	2	CARBON BRUSH	
K1	9099309000	1	DECALS SC450 NIL KIT	
K2	9099310000	1	GASKETS VACUUM MOTOR KIT	
K3	9099311000	1	GASKETS KIT	
K4	9100000767	1	LEVER SQUEEGEE LIFTING KIT	
K5	9100000768	1	HARDWARE SOLUTION TANK KIT	

# RECOVERY TANK

SC450 B

14-04-2015

Part List ID  
SC450B020

7

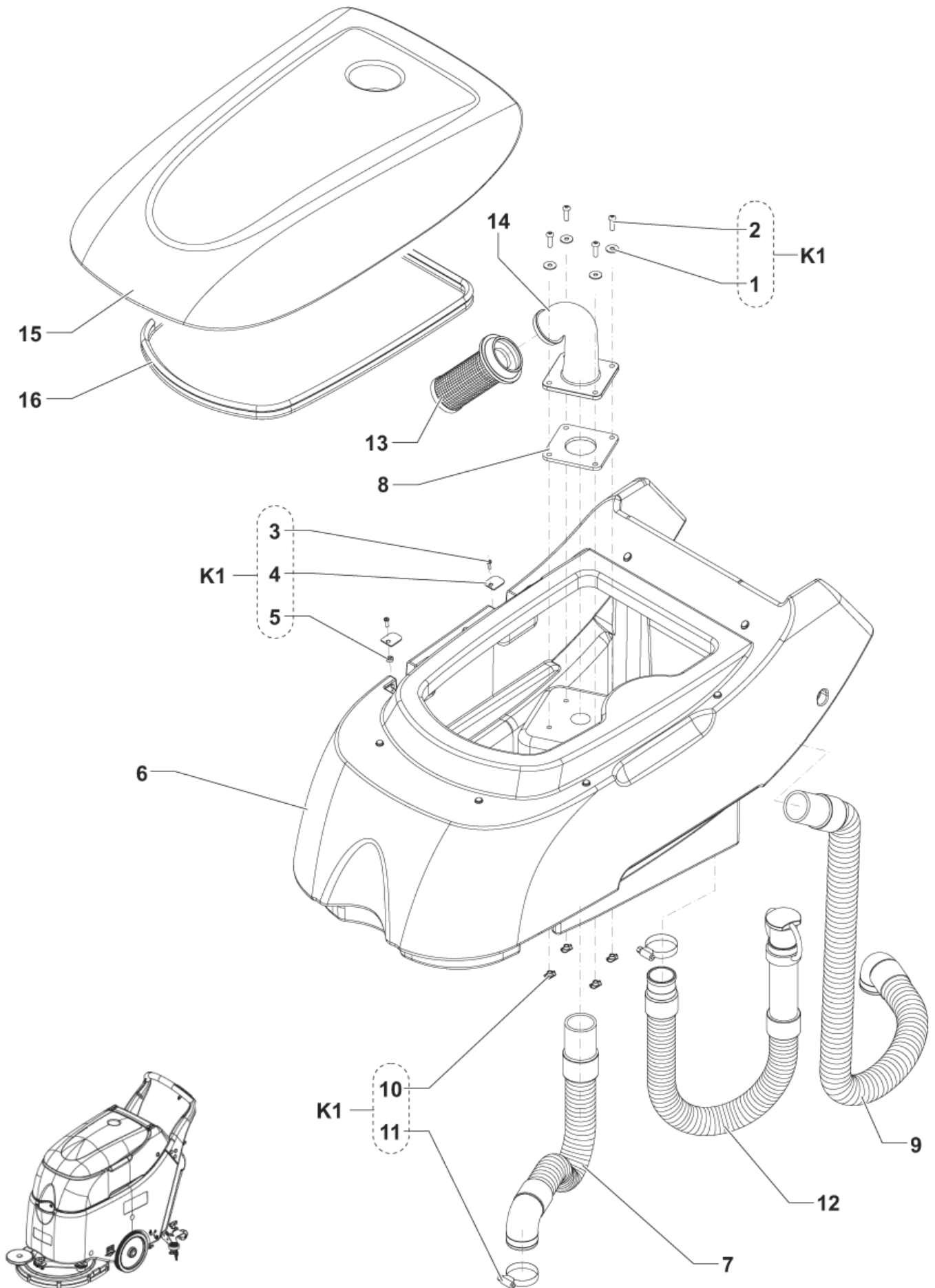

# RECOVERY TANK

SC450 B

14-04-2015

Part List ID  
SC450B020

8

Pos	Part no.	Qty	Description	
6	9099252000	1	TANK RECOVERY	
7	9099255000	1	HOSE VACUUM MOTOR	
8	9100000912	1	GASKET FLOAT CAGE HOLDER PKD	
9	9100000642	1	HOSE SUCTION BLACK PKD	
12	9099692000	1	HOSE DRAIN BLACK PKD	
13	9099559000	1	FLOAT SHUT OFF	
14	9099558000	1	ELBOW FLOAT HOLDER	
15	9099253000	1	COVER TANK	
16	9099342000	1	GASKET BULB RUBBER L.1350MM PKD	
17	909 5065 000	1	FILTER ANTIFOAMING	OPTION - NOT SHOWN
K1	9099313000	1	HARDWARE RECOVERY TANK KIT	



# HANDLE BAR AND WHEELS

SC450 B

14-04-2015

Part List ID  
SC450B030

9

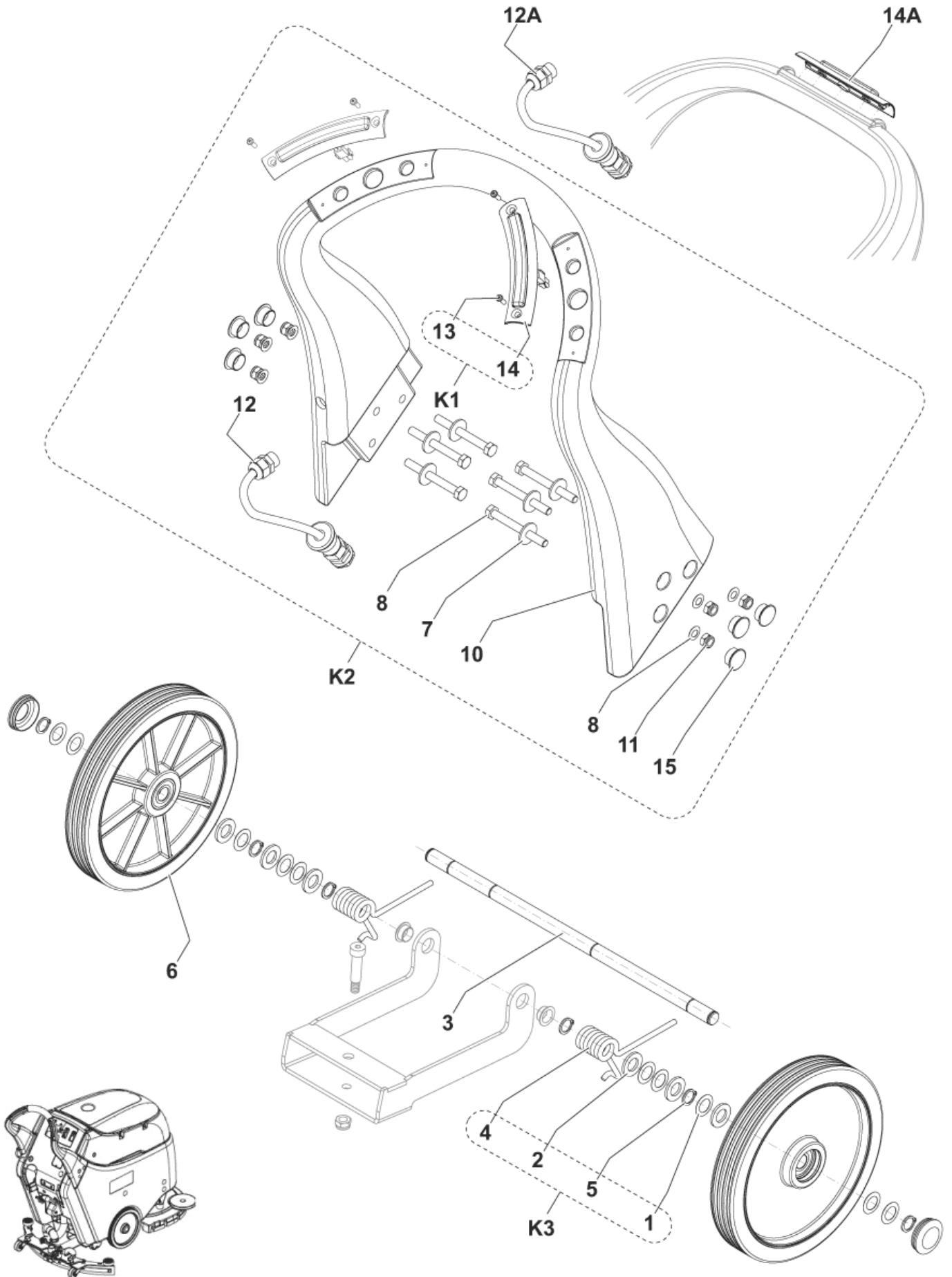

# HANDLE BAR AND WHEELS

SC450 B

14-04-2015

Part List ID  
SC450B030

10

Pos	Part no.	Qty	Description	
3	9099256000	1	SHAFT WHEELS	
6	9099270000	2	WHEEL D.254	
10	9100000564	1	HANDLE BAR GREY PKD	
12	9100000565	1	HARNESS HANDLE BAR PKD	
K1	9100000466	1	SWITCHES CPL BLACK F HANDLE BAR KIT	
K2	9100000425	1	HANDLE BAR GREY KIT	INST.INSTR. 9100000465
K3	9100000566	1	HARDWARE WHEELS KIT	
12A	9099285000	1	HARNESS HANDLE BAR	FOR OLD HANDLE BAR MODEL WITH ONE SWITCH
14A	11178A	1	SWITCH HANDLE ASSY	FOR OLD HANDLE BAR MODEL WITH ONE SWITCH

# SOLUTION SYSTEM

SC450 B

14-04-2015

Part List ID  
SC450B040

11

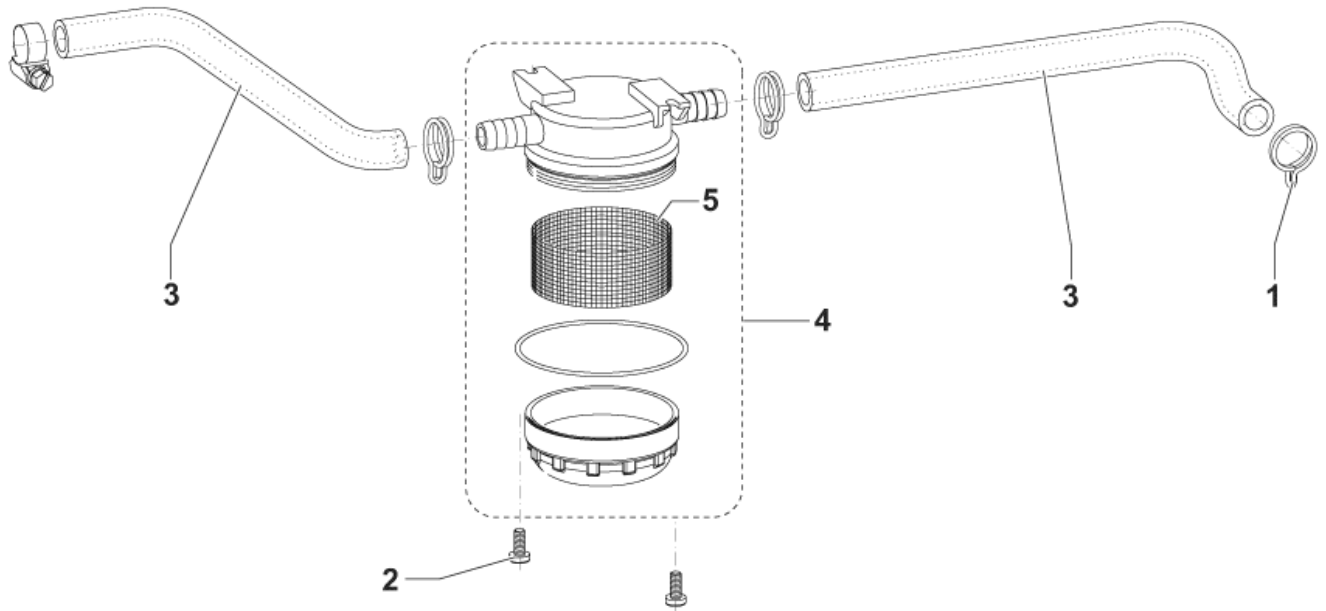

# SOLUTION SYSTEM

SC450 B

14-04-2015

Part List ID  
SC450B040

12

Pos	Part no.	Qty	Description
0	9099481000	1	NET WATER FILTER REINFORCED
1	9100000511	1	CLAMPS F SOLUTION SYSTEM KIT includes both 09/12-22 and DOUBLE WIRE SPRING D.18
2	909 5009 000	2	SCREW M5X12 PAN HD PHIL SS ISO7045
3	9099337000	1	HOSE D.12 KIT
4	9100000362	1	FILTER WATER
5	9099481000	1	NET WATER FILTER REINFORCED

POSITION 1: includes both CLAMPS 09/12-22 and CLAMPS DOUBLE WIRE SPRING D.18 - total 7 pieces

# SQUEEGEE SYSTEM

SC450 B

14-04-2015

Part List ID  
SC450B050

13

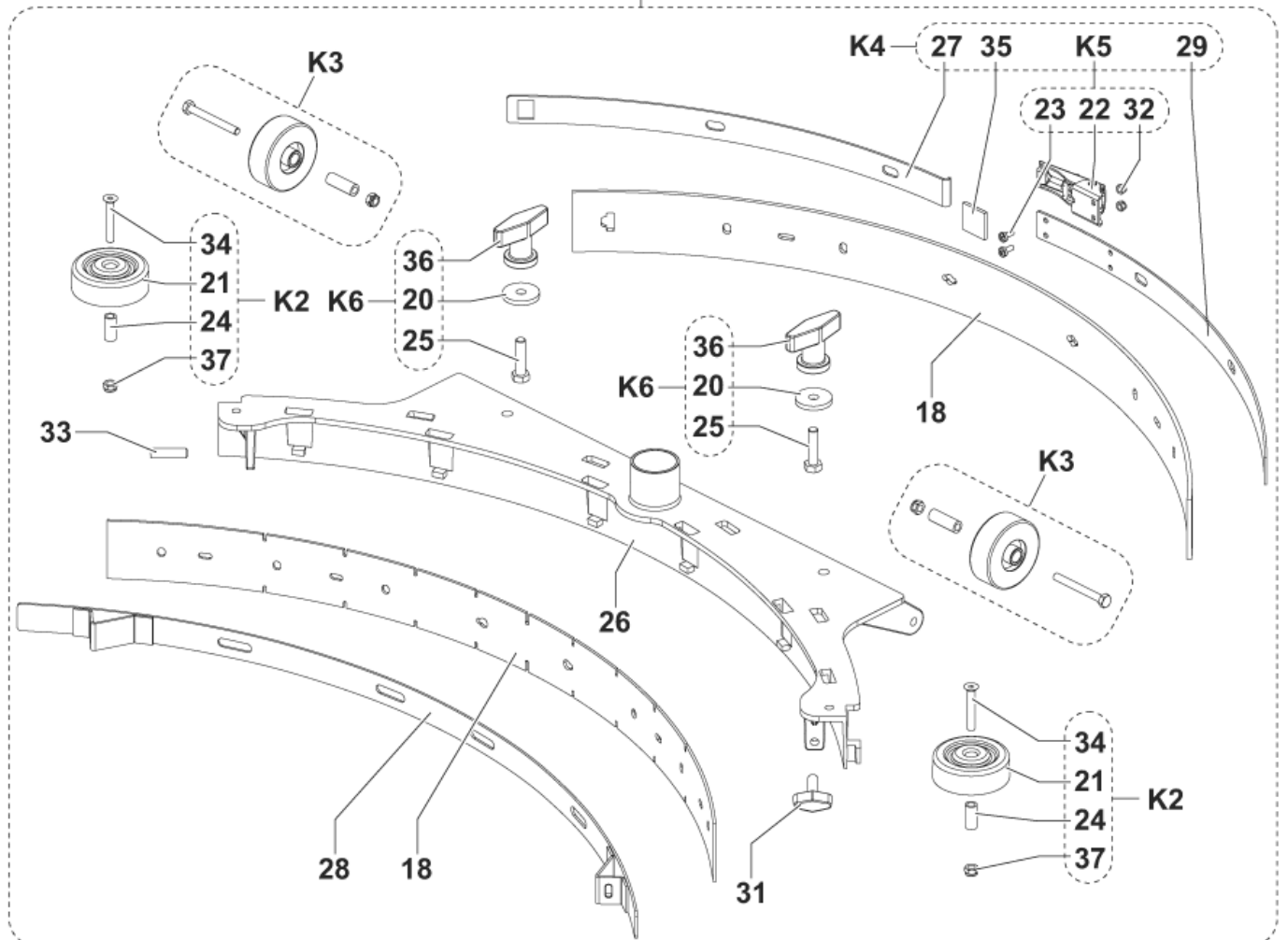
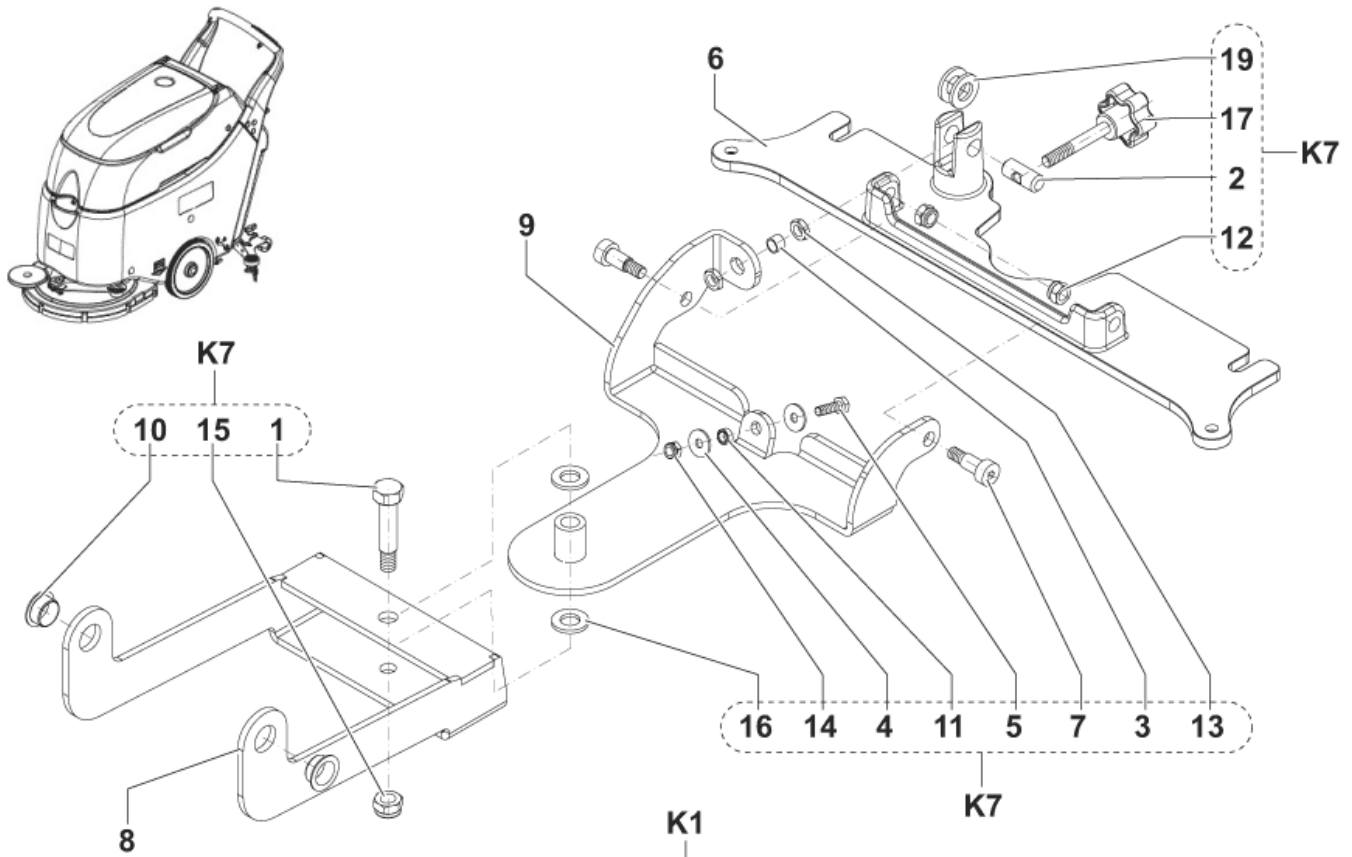

# SQUEEGEE SYSTEM

SC450 B

14-04-2015

Part List ID  
SC450B050

14

Pos	Part no.	Qty	Description	
6	909 6045 000	1	SUPPORT. SQUEEGEE	
8	9100000509	1	SUPPORT FRONT F SQUEEGEE PKD	
9	9100000510	1	SUPPORT REAR F SQUEEGEE PKD	
18	909 6858 000	1	BLADE SQUEEGEE 740MM 29 PU KIT	OPTION
18	9100000279	1	BLADES NON MARKING 740MM/29 KIT	
26	909 6044 000	1	WELDMENT.SQUEEGEE TOOL	
28	909 6055 000	1	STRAP.SQUEEGEE FRONT	
31	9100000791	1	KNOB M8X30 THD STUD SS PKD	
33	909 6600 000	1	SCREW GRUB M8X30 CUP POINT SS ISO4029	
K1	909 6851 000	1	SQUEEGEE CPL ALU 760MM/30 KIT	
K2	909 6884 000	1	ROLLER BUMPER SQUEEG.KIT	
K3	909 6883 000	1	WHEELS SQUEEGEE 60X20MM KIT	
K4	909 6882 000	1	HARDWARE SQU.BLADE FIXING KIT	
K5	909 6394 000	1	LATCH SQUEEGEE KIT	
K6	9097637000	1	SQUEEGEE FIXING KIT	
K7	9099322000	1	HARDWARE SQUEEGEE SUPPORT KIT	

# BRUSH DECK

SC450 B

14-04-2015

Part List ID  
SC450B060

15

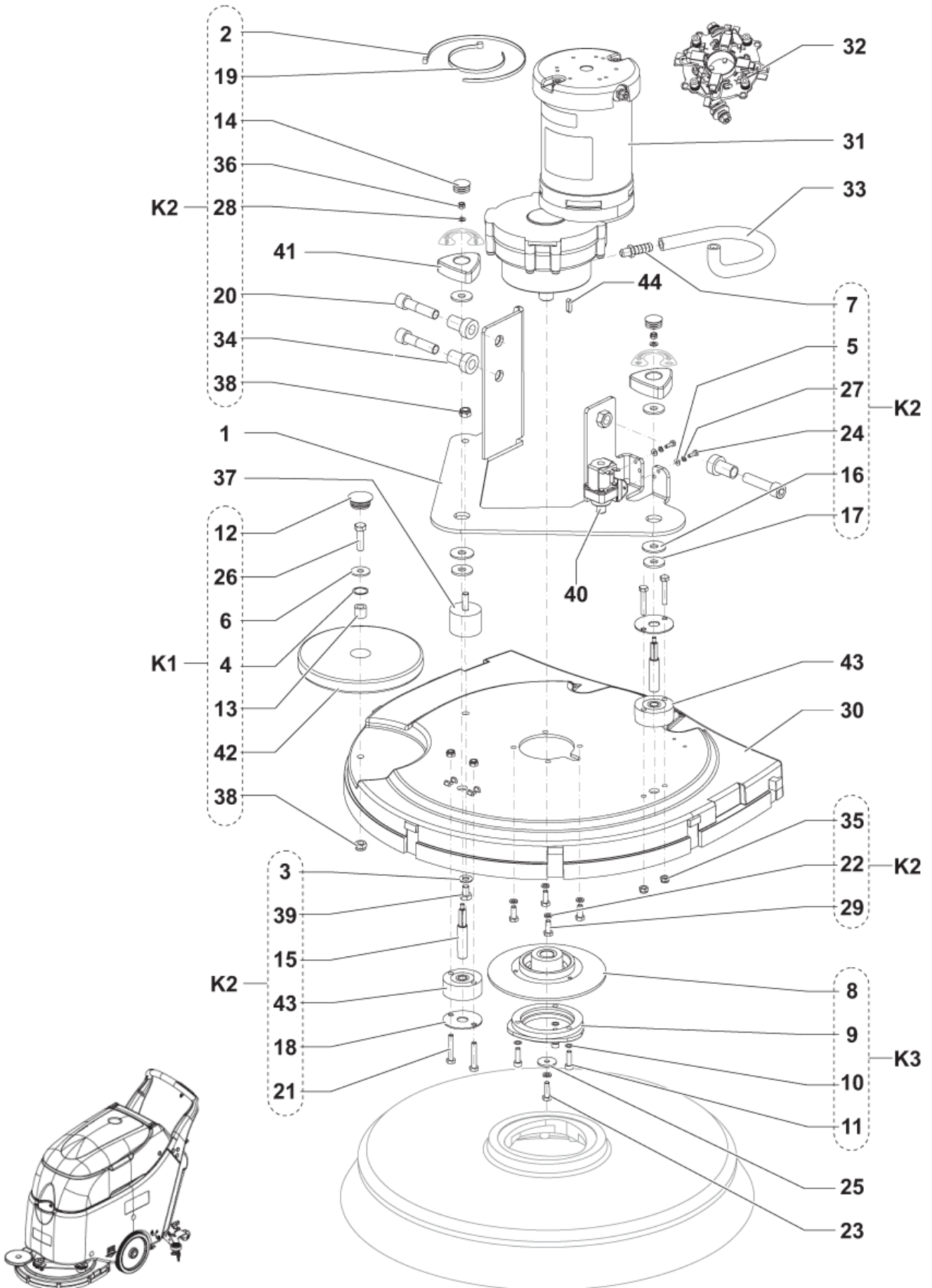

# BRUSH DECK

SC450 B

14-04-2015

Part List ID  
SC450B060

16

Pos	Part no.	Qty	Description	
1	910000572	1	PLATE BLACK BRUSH DECK HOLDER PKD	
8	L08812306	1	HUB BRUSH R.GEARMOTOR RIGHT	
9	L08812480	1	HUB.BRUSH	
23	145 0492 000	1	SCREW M6X25 HEX HD F/THD SS ISO4017	
30	909 6042 000	1	DECK BRUSH	
31	9099324000	1	REDUCTION GEARMOTOR 480W 24V KIT	OLD MOD.LEROY S. GM462200 - TILL SN 3510134507872
31	910000454	1	REDUCTION GEARMOTOR 480W 24V KIT	SEE NOTE - NEW MOD.LEROY S.GM515200
32	909 5380 000	1	CARBON BRUSHES W/HOLDER KIT 4PCS	OLD MOD.LEROY S. GM462200 - TILL SN 3510134507872
32	910000421	1	CARBON BRUSHES W/HOLDER KIT	NEWMOD.LEROY S.GM515200
33	9099341000	1	HOSE POLYESTER REINF. D.10 L.250 KIT	
37	910000868	1	VIBRATION DAMPING M8 60SH 2 PCS SET	
40	9099563000	1	SOLENOID VALVE 24V	
41	L08812203	2	KNOB	
43	L08812213	2	BUFFER	
44	1466147000	1	KEY 5X5X20 UNI6604A PKD	
K1	909 6887 000	1	ROLLER BUMPER KIT	
K2	9099326000	1	HARDWARE BRUSH DECK KIT	
K3	L08812589	1	HUB BRUSH KIT	



# CONTROL PANEL

SC450 B

14-04-2015

Part List ID  
SC450B070

17

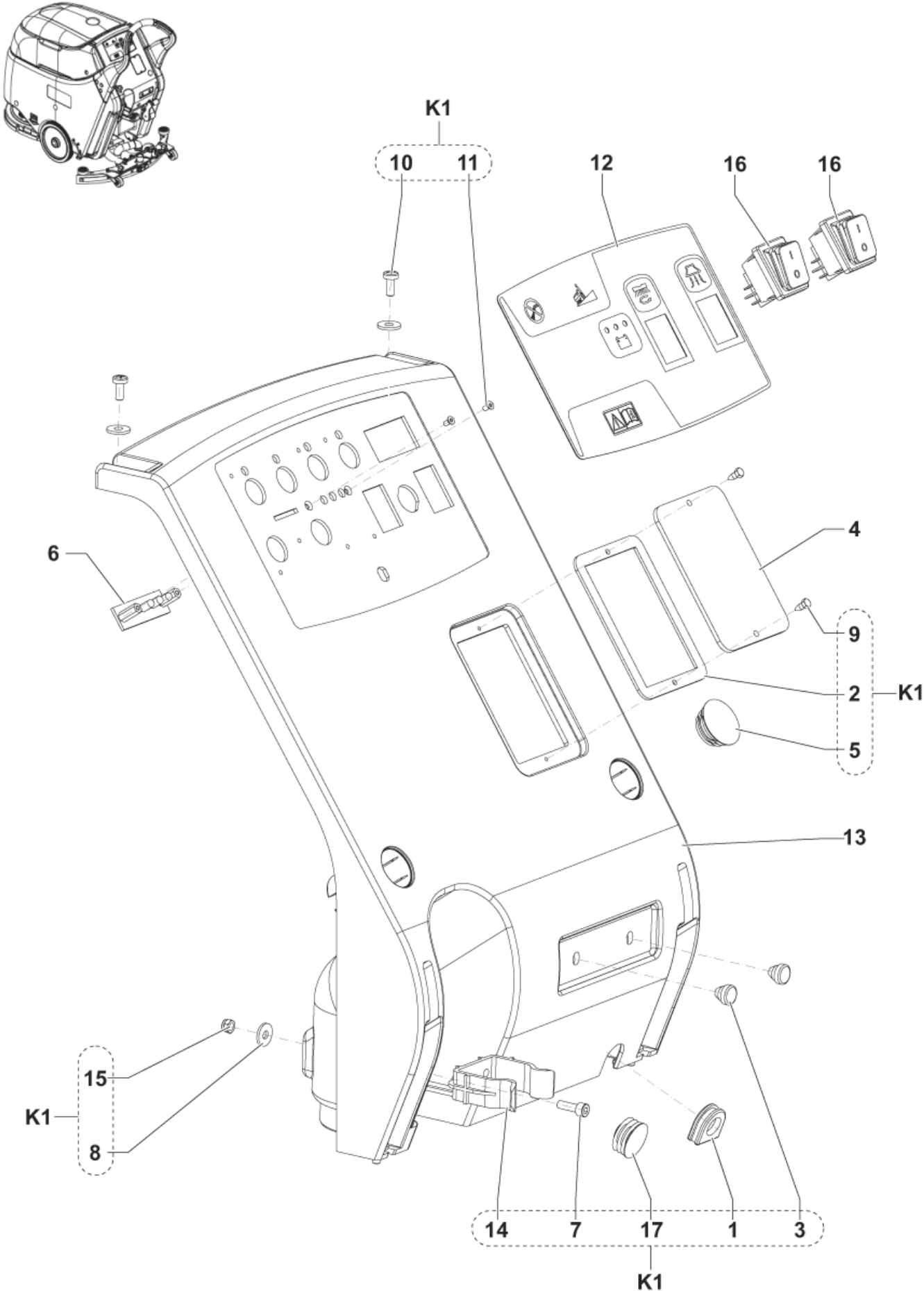

# CONTROL PANEL

SC450 B

14-04-2015

Part List ID  
SC450B070

18

Pos	Part no.	Qty	Description
4	910001065	1	COVER F INSPECTION PLATE BLACK PKD
6	L08812909	1	BOARD. LED
12	910000943	1	DECAL CONTROL PANEL PKD
13	9099279000	1	COVER BOX ELECTRIC COMP.
16	107404540	2	SWITCH 0-1 DOUBLE POLE SET
K1	9099327000	1	HARDWARE CONTROL PANEL BA KIT

# ELECTRICAL COMPONENTS

SC450 B

14-04-2015

Part List ID  
SC450B080

19

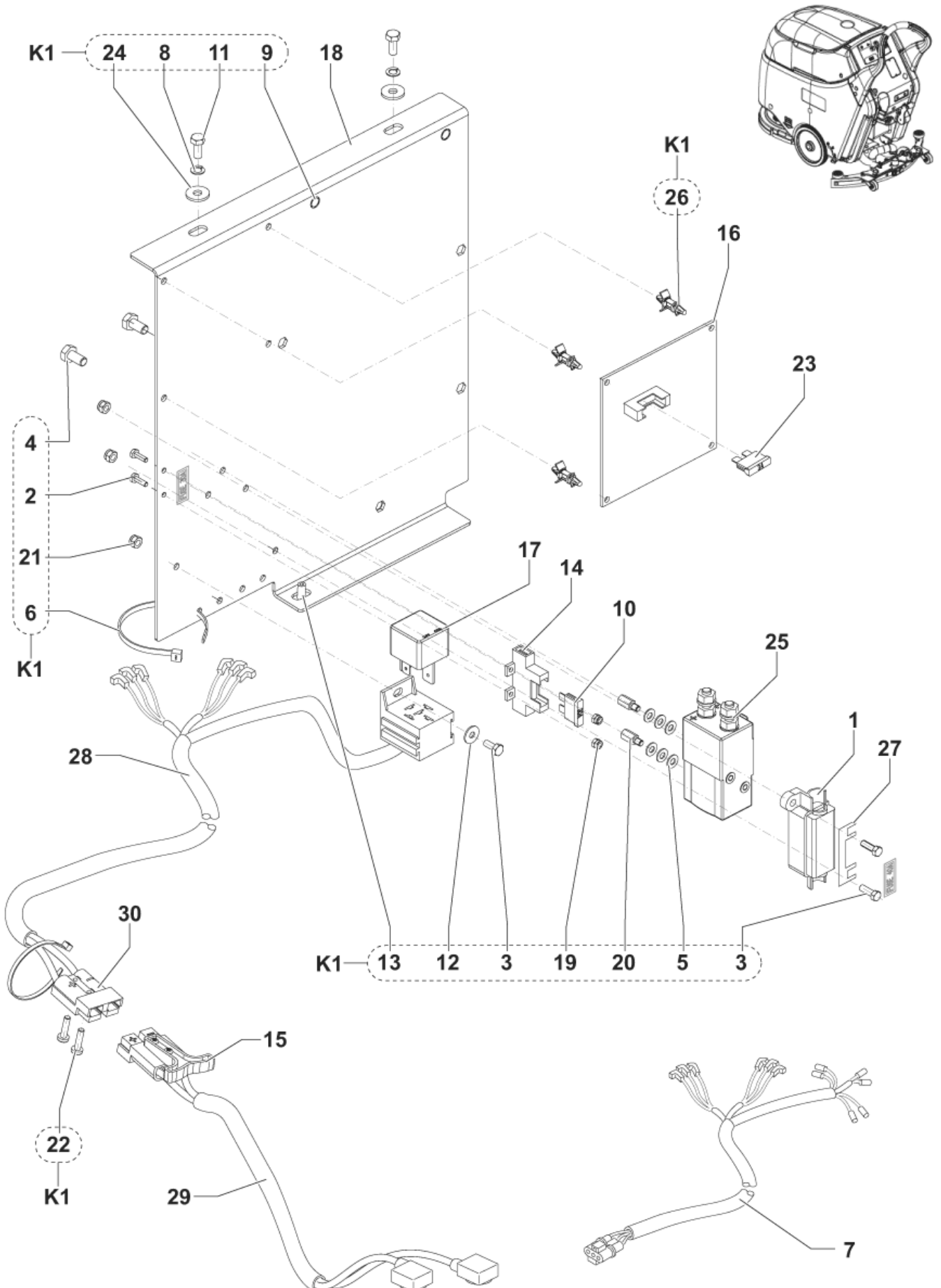

# ELECTRICAL COMPONENTS

SC450 B

14-04-2015

Part List ID  
SC450B080

20

Pos	Part no.	Qty	Description	
0	9096951000	1	COUNTER HOUR 24V KIT	see note
0	910000949	1	HOUR COUNTER ADAPTOR KIT	before S/N
1	145 8046 000	1	HOLDER FUSE	
7	9099268000	1	HARNESS MACHINE	
10	145 8513 000	1	FUSE BLADE 30A UL	
14	146 0660 000	1	HOLDER FUSE THERMOPL. UL 94-V0	
15	1464116000	1	HANDLE RED PLASTIC SB 120	
16	9099967000	1	CARD ELECTRONIC PKD	
17	909 6622 000	1	RELAY 24V 40A	
18	909 6498 000	1	SUPPORT ELECTRIC COMP.	
23	145 9852 000	1	FUSE BLADE 5A UL	
25	146 0719 000	1	SWITCH ELECTROMAGNETIC 24V	
27	145 3824 000	1	FUSE STRIP 40A	
27	9100000778	1	FUSE STRIP 30A KIT	INST INSTR 9100000777
28	9100001196	1	HARNESS ELECTRIC COMP. BOX PKD	
29	L08603889	1	HARNESS BATTERY	
30	9098761000	2	CONNECTOR 50A RED	
K1	9099328000	1	HARDWARE ELECTRIC COMP. KIT	

NOTE: POSITION 0 9096951000: IT COULD BE ASSEMBLED BOTH ON MACHINES AFTER SERIAL NUMBER XXXXXXXX AND BEFORE SERIAL NUMBER XXXXXXXX, BUT ONLY IF THOSE LAST MACHINES ARE EQUIPPED WITH THE 910000949 ( see

# ACCESSORIES

SC450 B

14-04-2015

Part List ID  
SC450B090

21

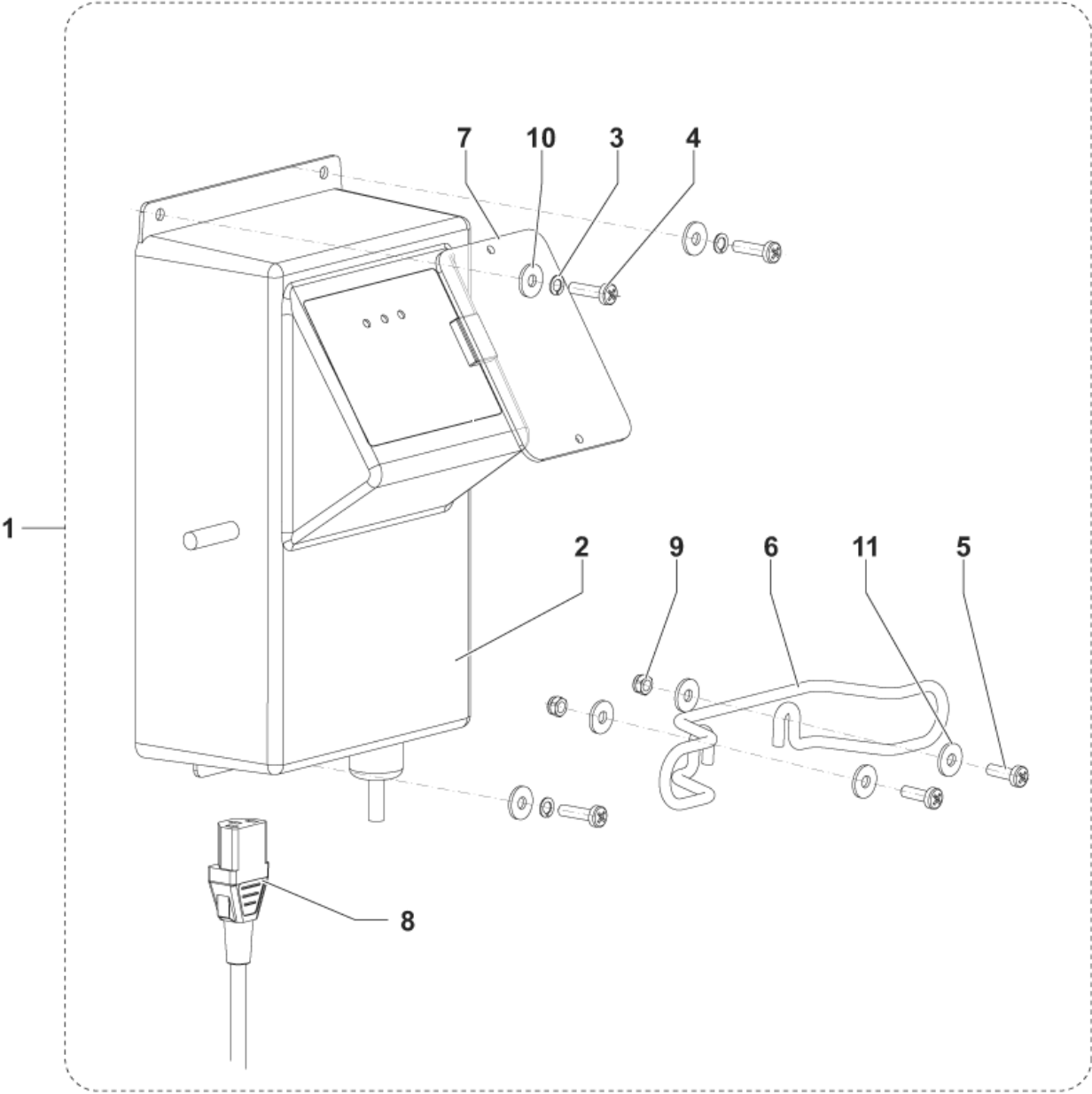

# ACCESSORIES

SC450 B

14-04-2015

Part List ID  
SC450B090

22

Pos	Part no.	Qty	Description
1	909 6739 000	1	CHARGER BATT. O/B 24V 13A 100-230V KIT OPT.INST.INSTR.909 6746 000
2	9098297000	1	CHARGER BATT. O/B 24V 13A 100-230V EU
5	146 2090 000	2	SCREW M5X16 PAN HD PHIL ISO7045
6	1466317000	1	SUPPORT CABLE KIT
7	9100001064	1	COVER F INSPECTION PLATE TRANSP. PKD
8	909 5676 000	1	CABLE EXTENSION UK PLUG L.1000MM
8	9096914000	1	CABLE EXTENSION US PLUG L.1500MM
8	9100000790	1	CABLE EXTENSION EU PLUG L.1000MM PKD
9	33005603	2	NUT SELF L. M5 UNI7474
11	145 1261 000	2	WASHER 5X15X1.5 UNI6593

# ACCESSORIES

SC450 B

14-04-2015

Part List ID  
SC450B100

23

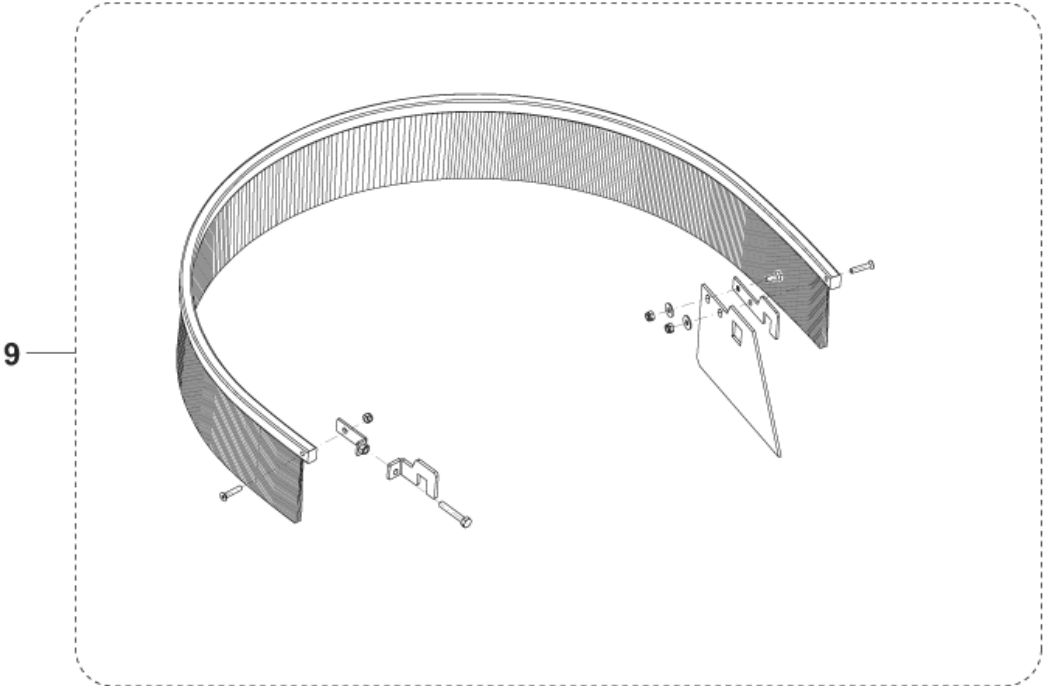
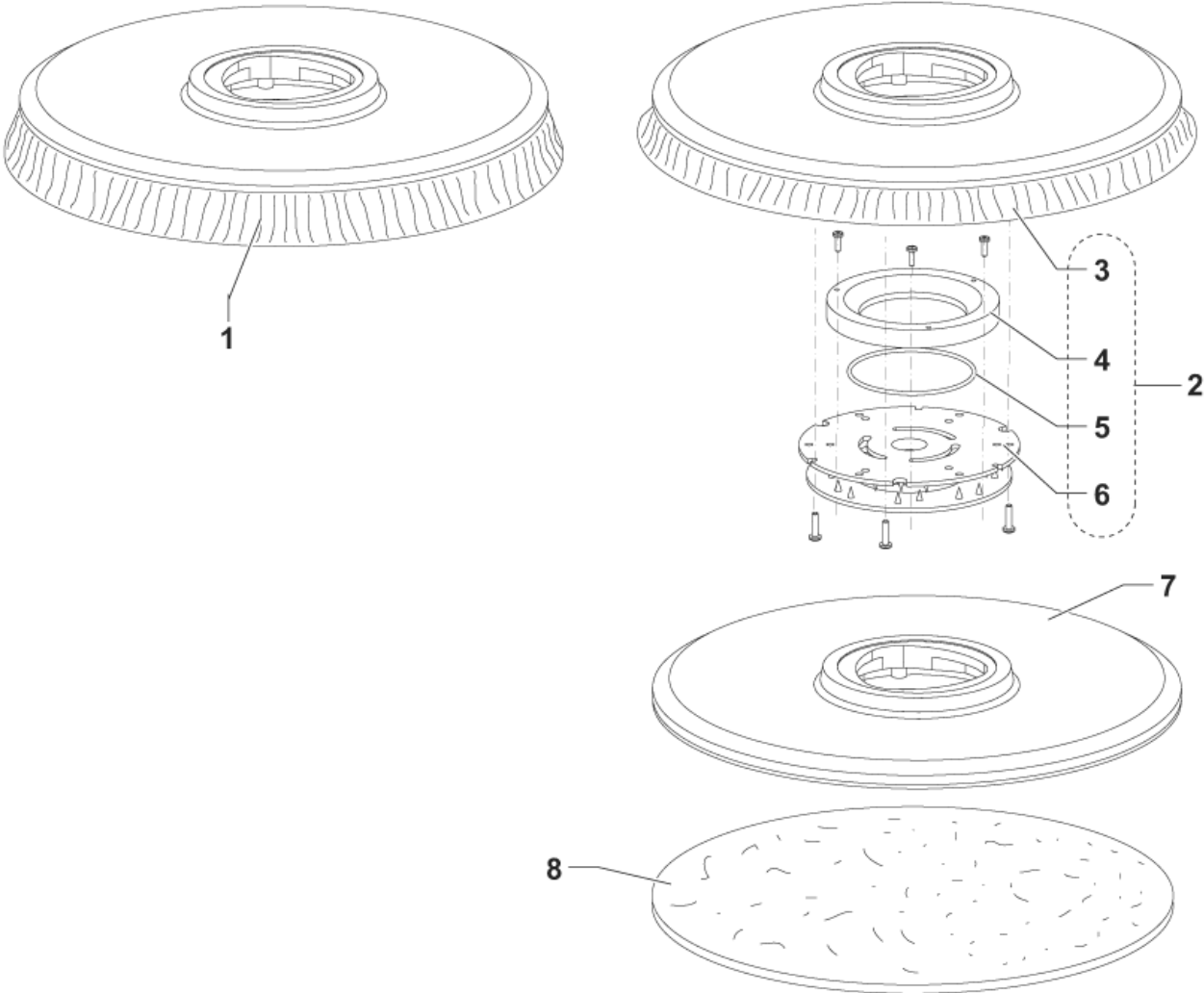

# ACCESSORIES

SC450 B

14-04-2015

Part List ID  
SC450B100

24

Pos	Part no.	Qty	Description	
1	L08837025	1	BRUSH DISC 530MM 21 PROLENE	OPTION
1	L08837026	1	BRUSH DISC 530MM 21 PROLITE	OPTION
1	L08837027	1	BRUSH DISC 530MM 21 UNION MIX	OPTION
1	L08837028	1	BRUSH DISC 530MM 21 MIDLITE GRIT 180	OPTION
1	L08837029	1	BRUSH DISC 530MM 21 MID GRIT 240	OPTION
1	L08837065	1	BRUSH DISC 530MM 21 MAGNA GRIT 46	OPTION
1	L08837066	1	BRUSH DISC 530MM 21 DYNA GRIT 80	OPTION
1	L08837067	1	BRUSH DISC 530MM 21 AGLITE GRIT 500	OPTION
2	L08837018	1	PAD HOLDER 530MM	OPTION
4	L08603966	1	RING NYLON	
5	L08603965	1	O-RING 2.62X82.22 -3325-NBR 40SH	
6	56505195	1	PAD RETAINER	
7	9099671000	1	PAD HOLDER FLAT 20 508MM	OPTION
8	10001954	1	PAD 20 508MM ECO TAN 5PCS	OPTION
8	10001955	1	PAD 20 508MM ECO BLACK 5PCS	OPTION
8	10001956	1	PAD 20 508MM ECO BLUE 5PCS	OPTION
8	10001957	1	PAD 20 508MM ECO BROWN 5PCS	OPTION
8	10001958	1	PAD 20 508MM ECO GREEN 5PCS	OPTION
8	10001959	1	PAD 20 508MM ECO RED 5PCS	OPTION
8	10001960	1	PAD 20 508MM ECO WHITE 5PCS	OPTION
8	10002348	1	PAD 20 508MM ECO BRILLIANCE RED 2PCS	OPTION
8	10002349	1	PAD 20 508MM ECO BRILLIANCE BLUE 2PCS	OPTION
8	10002350	1	PAD 20 508MM ECO BRILLIANCE YELLOW 2PCS	OPTION
8	10002351	1	PAD 20 508MM ECO BRILLIANCE GREEN 2PCS	OPTION
9	909 6736 000	1	SPLASH GUARD KIT 530MM/21	OPTION - INST. INSTRUCTION 909 6745 000



# WIRING DIAGRAM

SC450 B

14-04-2015

Part List ID  
SC450B110

25

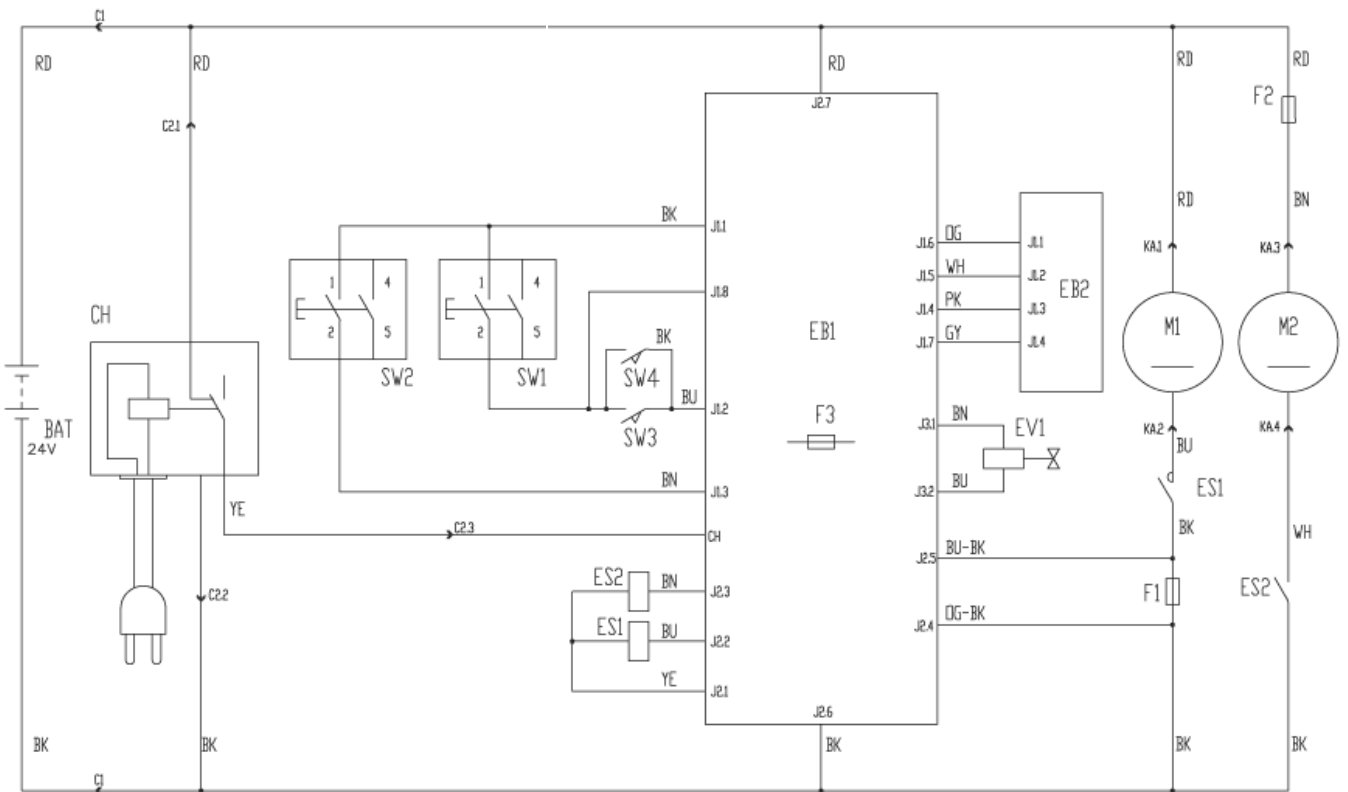

# WIRING DIAGRAM

SC450 B

14-04-2015

Part List ID  
SC450B110

26

Pos	Part no.	Qty	Description
C1	9098761000	1	CONNECTOR 50A RED
CH	9098297000	1	CHARGER BATT. O/B 24V 13A 100-230V EU
F1	145 3824 000	1	FUSE STRIP 40A
F2	145 8513 000	1	FUSE BLADE 30A UL
F3	145 9852 000	1	FUSE BLADE 5A UL
M1	9100000454	1	REDUCTION GEARMOTOR 480W 24V KIT
M2	9099922000	1	MOTOR VACUUM 330W 24V KIT
EB1	9099967000	1	CARD ELECTRONIC PKD
EB2	L08812909	1	BOARD. LED
ES1	146 0719 000	1	SWITCH ELECTROMAGNETIC 24V
ES2	909 6622 000	1	RELAY 24V 40A
EV1	9099563000	1	SOLENOID VALVE 24V
SW1	107404540	1	SWITCH 0-1 DOUBLE POLE SET
SW2	107404540	1	SWITCH 0-1 DOUBLE POLE SET
SW3	11178A	1	SWITCH HANDLE ASSY FOR OLD HANDLE BAR MODEL WITH ONE SWITCH
SW3	9100000466	1	SWITCHES CPL BLACK F HANDLE BAR KIT
SW4	9100000466	1	SWITCHES CPL BLACK F HANDLE BAR KIT

# RECOMMENDED PARTS

SC450 B

14-04-2015

Part List ID  
SC450B120

27

No Drawing For Part List

# RECOMMENDED PARTS

SC450 B

14-04-2015

Part List ID  
SC450B120

28

Pos	Part no.	Qty	Description	
0	107404540	2	SWITCH 0-1 DOUBLE POLE SET	E O M
0	145 3824 000	1	FUSE STRIP 40A	E O M
0	145 8513 000	1	FUSE BLADE 30A UL	E O M
0	145 9852 000	1	FUSE BLADE 5A UL	E O M
0	146 0719 000	1	SWITCH ELECTROMAGNETIC 24V	E O M
0	909 5371 000	1	CARBON BRUSH	N W
0	909 5380 000	1	CARBON BRUSHES W/HOLDER KIT 4PCS	N W
0	909 6622 000	1	RELAY 24V 40A	E O M
0	909 6736 000	1	SPLASH GUARD KIT 530MM/21	N W
0	909 6887 000	1	ROLLER BUMPER KIT	E O M
0	9098297000	1	CHARGER BATT. O/B 24V 13A 100-230V EU	E O M
0	9098761000	2	CONNECTOR 50A RED	E O M
0	9099255000	1	HOSE VACUUM MOTOR	O M
0	9099258000	1	CABLE SQUEEGEE LIFTING	O M
0	9099268000	1	HARNESS MACHINE	E O M
0	9099270000	2	WHEEL D.254	O M
0	9099310000	1	GASKETS VACUUM MOTOR KIT	O M
0	9099311000	1	GASKETS KIT	O M
0	9099342000	1	GASKET BULB RUBBER L.1350MM PKD	O M
0	9099481000	1	NET WATER FILTER REINFORCED	O M
0	9099513000	1	VALVE ELBOW 90. D.13MM	O M
0	9099563000	1	SOLENOID VALVE 24V	O M
0	9099671000	1	PAD HOLDER FLAT 20 508MM	O M
0	9099692000	1	HOSE DRAIN BLACK PKD	O M
0	9099922000	1	MOTOR VACUUM 330W 24V KIT	O M
0	9099953000	1	WHEEL D.50	O M
0	9099967000	1	CARD ELECTRONIC PKD	E O M
0	910000279	1	BLADES NON MARKING 740MM/29 KIT	N W
0	910000362	1	FILTER WATER	O M
0	910000421	1	CARBON BRUSHES W/HOLDER KIT	N W
0	910000454	1	REDUCTION GEARMOTOR 480W 24V KIT	O M
0	910000466	1	SWITCHES CPL BLACK F HANDLE BAR KIT	E O M
0	910000642	1	HOSE SUCTION BLACK PKD	O M
0	910000868	1	VIBRATION DAMPING M8 60SH 2 PCS SET	O M
0	910000943	1	DECAL CONTROL PANEL PKD	E O M
0	910001196	1	HARNESS ELECTRIC COMP. BOX PKD	E O M
0	L08837018	1	PAD HOLDER 530MM	O M
0	L08837025	1	BRUSH DISC 530MM 21 PROLENE	N W