

# SALTIX 10, SALTIX 10 C, ALTO 101D

---

Model:  
GD 1005  
GD 111 ALTO  
SALTIX 10  
SALTIX 10 C



Part List US-English

07-06-2011

**Nilfisk**  
**ALTO**  
works for you

[www.nilfisk-alto.com](http://www.nilfisk-alto.com)

# Table of Contents

SALTIX 10, SALTIX 10 C, ALTO 101D

<b>Summary ALTO 101D, SALTIX 10 C</b>	<b>3</b>
<b>Summary SALTIX 10</b>	<b>5</b>
<b>Accessories</b>	<b>7</b>
<b>RECOMMENDED SPARE PARTS</b>	<b>9</b>

# Summary ALTO 101D, SALTIX 10 C

SALTIX 10, SALTIX 10 C, ALTO 101D

07-06-2011

Part List ID  
SALTIX1002

3

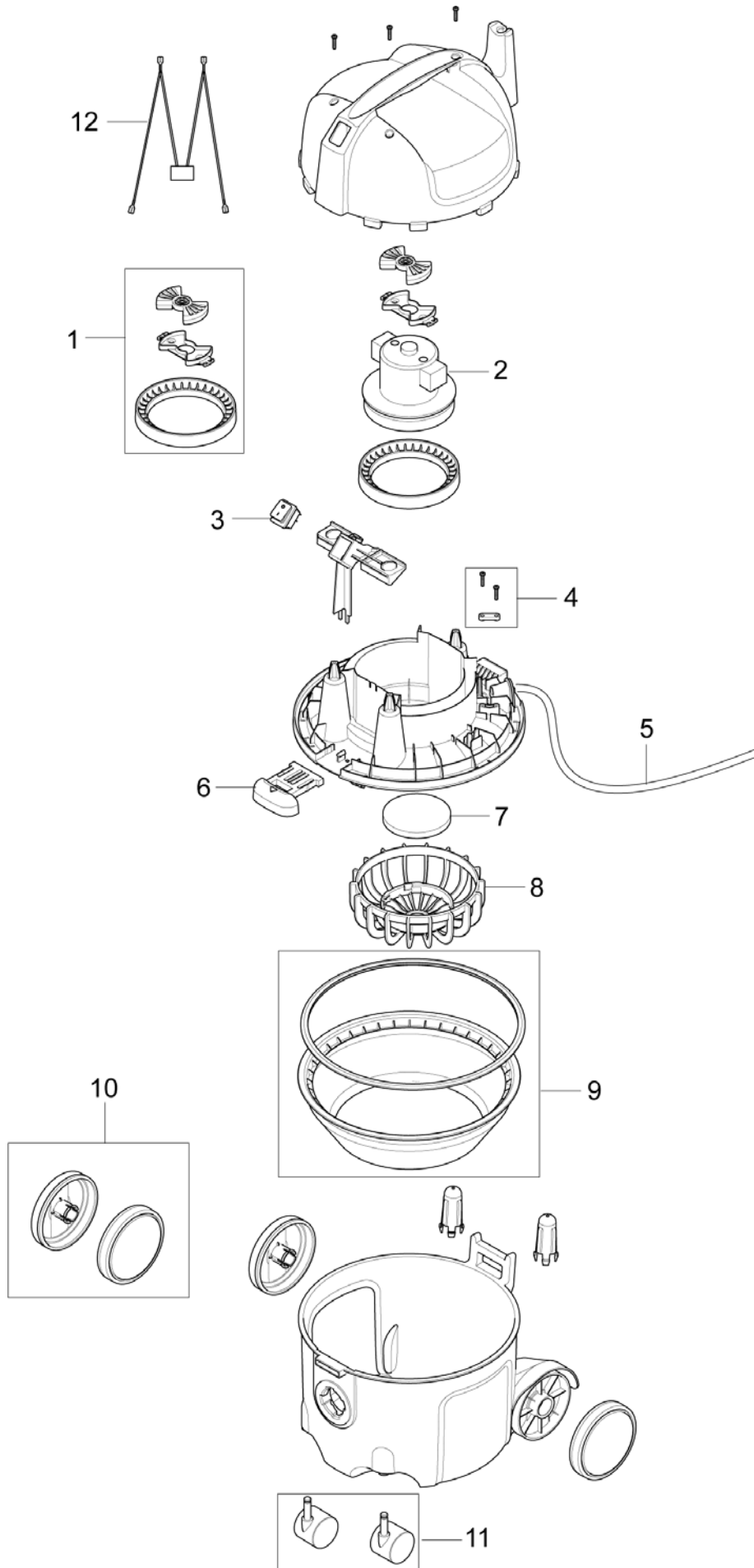

# Summary ALTO 101D, SALTIX 10 C

SALTIX 10, SALTIX 10 C, ALTO 101D

07-06-2011

Part List ID

SALTIX1002

4

Pos	Part no.	Qty	Description		EAN
0		1	BOX VC300 HEPA EU1 AND SALTIX 10		5703887112
0	147 1436 000	1	BOX GD111 AND SALTIX 10		5703887110
1	147 0660 500	1	MOTOR SUSPENSION KIT		7319519652
2	147 1428 500	1	FAN UNIT 230-240V 900W TCO	EU + CN	7319519673
3	140 9537 500	1	SWITCH TWO POLE 2 PCS		7319519639
4	140 6560 500	1	ANTI STRAIN CLIP		7319519640
5	140 6800 650	1	CORD SET 10M EU	EU	7319519673
5	147 0504 540	1	CORD SET 10.5M CHINA	CN	7319519673
6	147 1409 500	1	LATCH	Grey	7319519673
7	147 0670 500	1	FILTER MOTOR KIT		7319519651
8	147 0669 500	1	BASKET SACK FILTER		7319519651
9	147 1432 500	1	SACK FILTER CPL	Accessory	7319519673
10	140 8458 500	1	WHEEL REAR KIT		7319519632
11	140 8445 500	1	CASTOR WHEEL KIT		7319519629
12	140 7620 530	1	SUPPRESSOR EU/UK/AU/NZ		7319519640

# Summary SALTIX 10

SALTIX 10, SALTIX 10 C, ALTO 101D

07-06-2011

Part List ID  
SALTIX1004

5

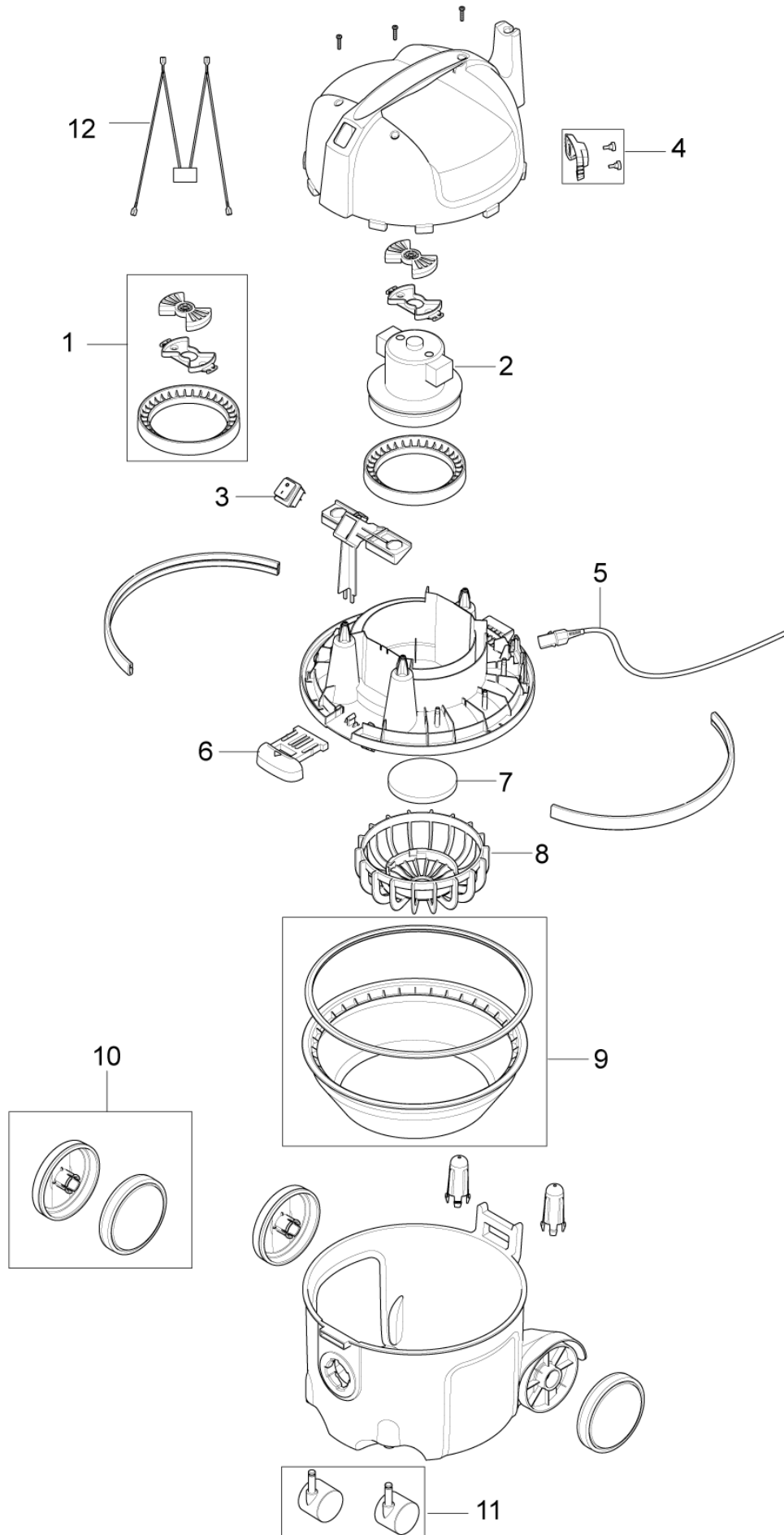

# Summary SALTIX 10

SALTIX 10, SALTIX 10 C, ALTO 101D

07-06-2011

Part List ID  
SALTIX1004

6

Pos	Part no.	Qty	Description	EAN
0		1	BOX VC300 HEPA EU1 AND SALTIX 10	5703887112
0		1	BOX KIT FOR THOR	5703887112
0	107403715	1	BOX KIT FOR ALTO	5703887112
0	147 1436 000	1	BOX GD111 AND SALTIX 10	5703887110
1	147 0660 500	1	MOTOR SUSPENSION KIT	7319519652
2	107402675	1	FAN UNIT 1200W TCO KIT	5703887110
3	140 9537 500	1	SWITCH TWO POLE 2 PCS	7319519639
4	107402674	1	CORD LOCK KIT	5703887110
5	107402676	1	DETACH CORD SET 10M ORANGE EU	5703887110
5	107402901	1	DETACH CORD SET 15M ORANGE EU	5703887112
6	147 1409 500	1	LATCH	7319519673
			Grey	
7	147 0670 500	1	FILTER MOTOR KIT	7319519651
8	147 0669 500	1	BASKET SACK FILTER	7319519651
9	147 1432 500	1	SACK FILTER CPL	7319519673
			Accessory	
10	140 8458 500	1	WHEEL REAR KIT	7319519632
11	140 8445 500	1	CASTOR WHEEL KIT	7319519629
12	140 7620 530	1	SUPPRESSOR EU/UK/AU/NZ	7319519640

# Accessories

SALTIX 10, SALTIX 10 C, ALTO 101D

07-06-2011

Part List ID  
SALTIX1005

7

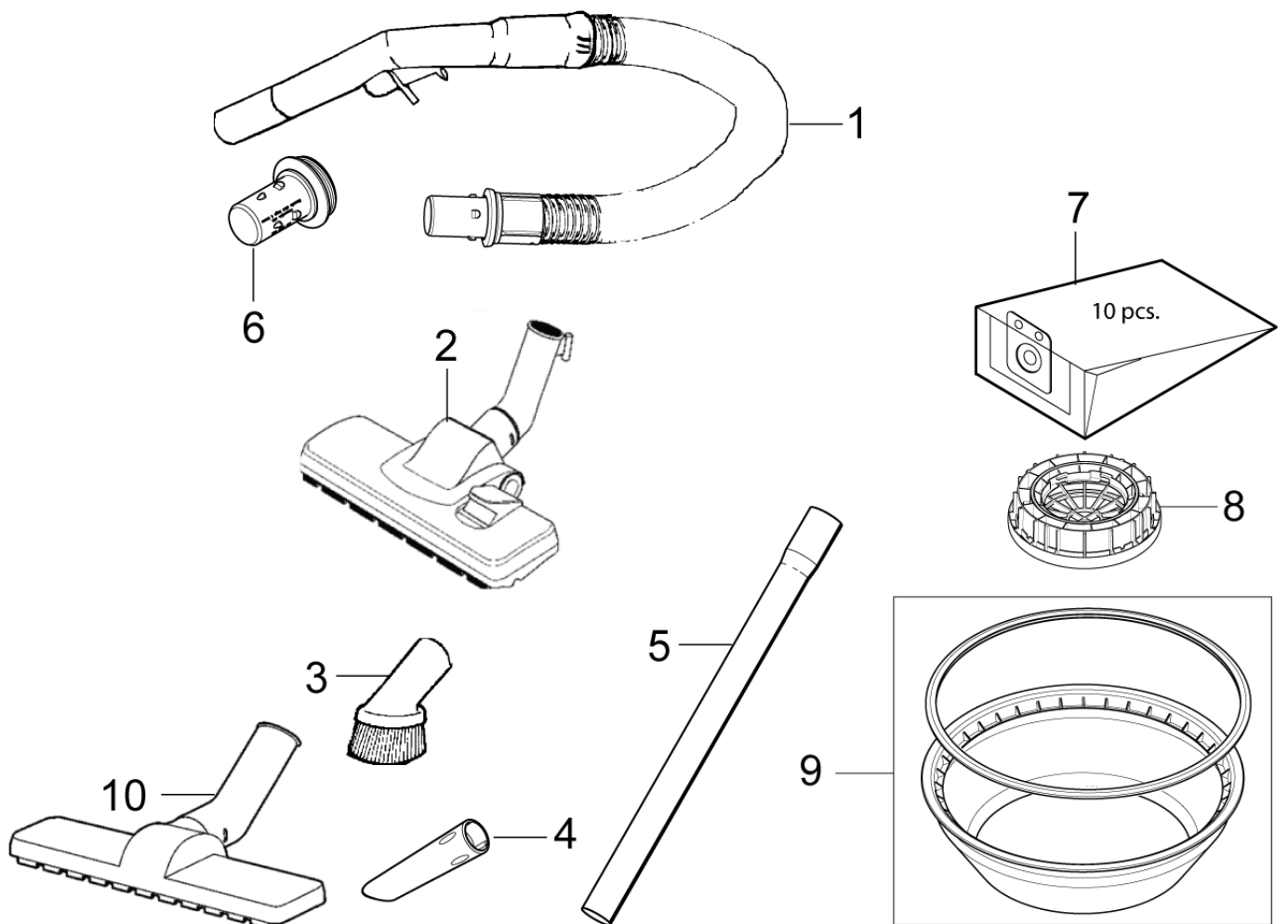

# Accessories

SALTIX 10, SALTIX 10 C, ALTO 101D

07-06-2011

Part List ID  
SALTIX1005

8

Pos	Part no.	Qty	Description	EAN
1	147 0765 500	1	HOSE CPL BLACK	7319519651
2	107403122	1	COMBI NOZZLE D252 KIT	5703887113
3	140 8244 500	1	BRUSH NOZZLE KIT	7319519658
4	147 0146 500	1	CREVICE NOZZLE D32 L153 BLACK	7319519647
5	011 6431 500	2	EXTENSION TUBE ALUMINIUM	7319519631
5	140 8246 040	2	EXTENSION TUBE STEEL D32	7319519607
6	107401199	1	20 PCS NUMATIC ADAPTER	5703887107
7	140 8618 000	1	DUST BAG 10L 10 PCS	7319519628
8	107402902	1	HEPA FILTER BOXED	ONLY SALTIX 10 5703887112
9	147 1432 500	1	SACK FILTER CPL	7319519673
10	140 6700 540	1	NOZZLE MULTI SURFACE 32 MM	7319519636



# RECOMMENDED SPARE PARTS

SALTIX 10, SALTIX 10 C, ALTO 101D

07-06-2011

Part List ID  
SALTIX1008

9

No Drawing For Part List

# RECOMMENDED SPARE PARTS

SALTIX 10, SALTIX 10 C, ALTO 101D

07-06-2011

Part List ID  
SALTIX1008

10

Pos	Part no.	Qty	Description		EAN
0	107402674	1	CORD LOCK KIT	SALTIX 10	5703887110
0	107402675	1	FAN UNIT 1200W TCO KIT	SALTIX 10	5703887110
0	107402676	1	DETACH CORD SET 10M ORANGE EU	SALTIX 10	5703887110
0	140 6560 500	1	ANTI STRAIN CLIP		7319519640
0	140 6800 650	1	CORD SET 10M EU	101D	7319519673
0	140 7620 530	1	SUPPRESSOR EU/UK/AU/NZ		7319519640
0	140 8445 500	1	CASTOR WHEEL KIT		7319519629
0	140 8458 500	1	WHEEL REAR KIT		7319519632
0	140 9537 500	1	SWITCH TWO POLE 2 PCS		7319519639
0	147 0504 540	1	CORD SET 10.5M CHINA	SALTIX 10C	7319519673
0	147 0660 500	1	MOTOR SUSPENSION KIT		7319519652
0	147 0669 500	1	BASKET SACK FILTER		7319519651
0	147 0670 500	1	FILTER MOTOR KIT		7319519651
0	147 1428 500	1	FAN UNIT 230-240V 900W TCO	101D, SALTIX 10C	7319519673
0	147 1432 500	1	SACK FILTER CPL		7319519673
0	147 1436 000	1	BOX GD111 AND SALTIX 10		5703887110