

**Loncin 隆鑫**

**汽油机零部件图册**

**DRAWING OF ENGINE**

**G420FD**

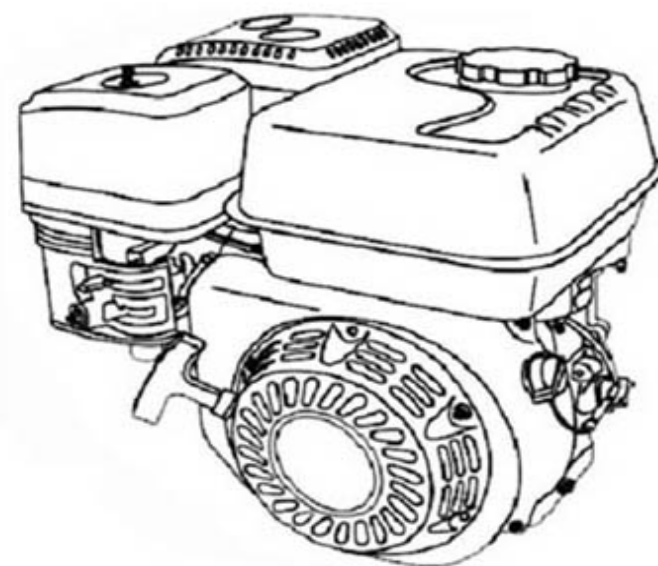

**隆鑫通用动力股份有限公司**

**LONGIN MOTOR CO., LTD**



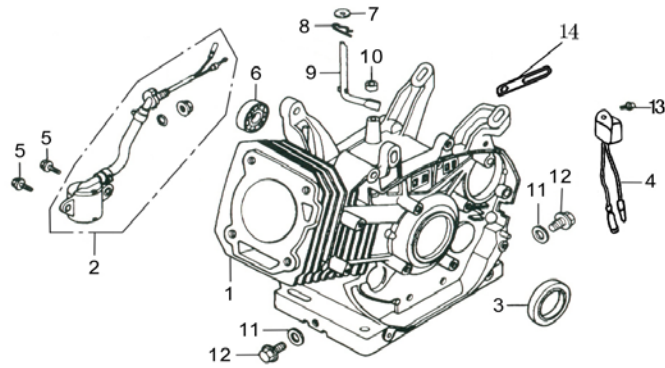

### 曲轴箱 (Crankcase)

序号 No.	零部件件号	零部件名称	Description	规格状态	数量	单位	易损属性
	Part No.				Reqd. QTY	UNIT	CONSUMABLE GRADE
1	110810035-0001	曲轴箱体	Crankcase body	T121_有孔;	1	件/PIECES	B
2	281850152-0001	油位传感器	Oil level sensor	T110_电感式;	1	套/SETS	A
3	380650337-0001	油封	Oil seal	T110_d=35_D=52_b=7;	1	件/PIECES	A
4	281890001-0001	机油保护器	Engine oil protector	T040;	1	件/PIECES	A
5	380140215-0003	六角头法兰面螺栓	Hexagon bolt with flange	GB/T 16674.1_M6_L=14;镀蓝白锌Q16	2	件/PIECES	C
6	380630099-0001	轴承	Bearing	GB/T 276_6202;	1	件/PIECES	B
7	380450522-0001	平垫圈	Flat washer	T110_T21_内径8_外径16_厚度1.2;镀白锌Q	1	件/PIECES	C
8	381350004-0001	销夹	Pin clip	T040_调速臂用;	1	件/PIECES	B
9	171630003-0001	调速臂	Speed regulating arm	T110;	1	件/PIECES	B
10	380650339-0001	油封	Oil seal	T110_d=8_D=14_b=4;	1	件/PIECES	A
11	380450516-0001	平垫圈	Flat washer	T110_T21_内径12_外径20_厚度2_铝及铝合	2	件/PIECES	C
12	110260024-0001	密封螺塞	Sealing plug screw	T110_M12×1.5×15;镀蓝白锌 Q16	2	件/PIECES	C
13	380140001-0006	六角头法兰面螺栓	Hexagon bolt with flange	GB/T 16674.1_M6_L=12;镀蓝白锌Q16	1	件/PIECES	C
14	380940346-0001	线夹	Cable cleat	T560;	1	件/PIECES	B







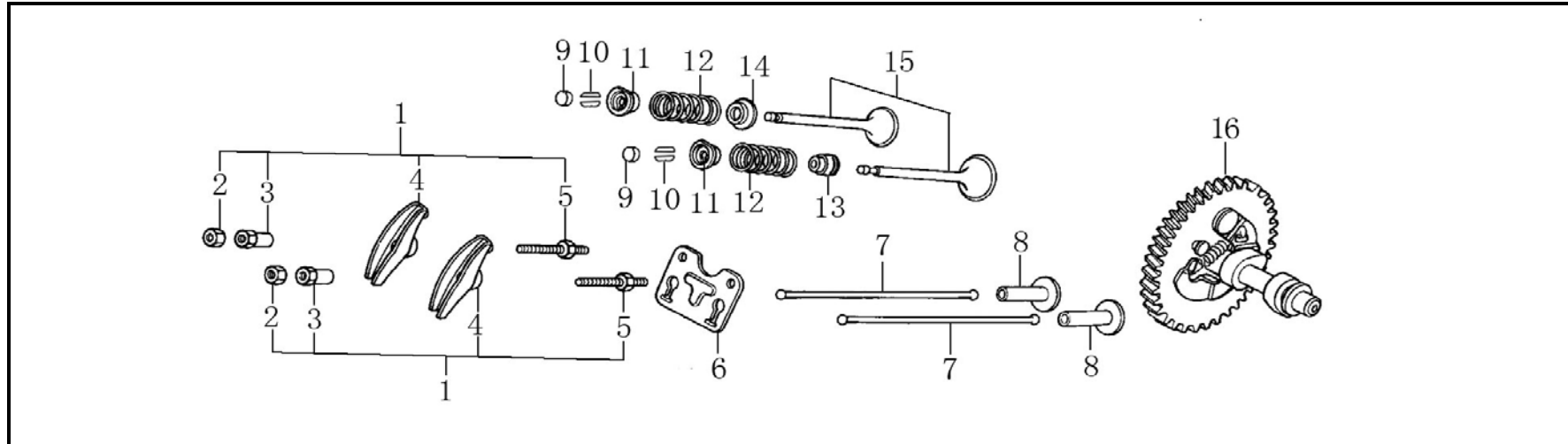

凸轮轴 (Camshaft)

序号 No.	零部件件号	零部件名称	Description	规格状态	数量	单位	易损属性
	Part No.				Reqd. QTY	UNIT	CONSUMABLE GRADE
1	140450023-0001	气门摇臂组合	Valve rocker combination	T110;	2	套/SETS	B
2	140470001-0001	气门锁紧螺母	Valve lock nut	T040;	2	件/PIECES	B
3	140490012-0001	气门调节螺母	Adjustable nut of valve	T040;	2	件/PIECES	B
4	140460024-0001	气门摇臂	Valve rocker	T110;	2	件/PIECES	B
5	140480012-0001	气门调节螺栓	Adjustable bolt of valve	T040;	2	件/PIECES	B
6	140710002-0001	推杆限位板组合	Plate, push rod guide	T110; 镀蓝白锌Q16	1	件/PIECES	B
7	140670006-0001	挺杆组合	Push rod	T110;	2	件/PIECES	B
8	140690004-0001	挺柱	Lifter, Valve	T110; 6#银白W02	2	件/PIECES	B
9	140320002-0001	气门调整帽	Valve adjustment cap	T110;	2	件/PIECES	B
10	140390015-0001	气门锁夹	Valve locker	T11D;	4	件/PIECES	B
11	140380021-0001	气门弹簧座	Retainer, valve spring	T11D_锁夹状态(通机)_排气门用	2	件/PIECES	B
12	140340025-0001	气门内弹簧	Inner spring of valve	T11D_调软状态;	2	件/PIECES	A
13	140400012-0001	挡油罩	Valve oil seal	T110;	1	件/PIECES	A
14	140360010-0001	气门内弹簧座圈	Seat, valve spring	T110;	1	件/PIECES	B
15	500550032-0001	气门套件	Valve Kit	T190_锁夹状态;	1	套/SETS	B
16	140020110-0001	凸轮轴组合	Camshaft assy	T190_增压, 全金属, 减压阀为甩掉	1	件/PIECES	B

















