

PARTS LIST

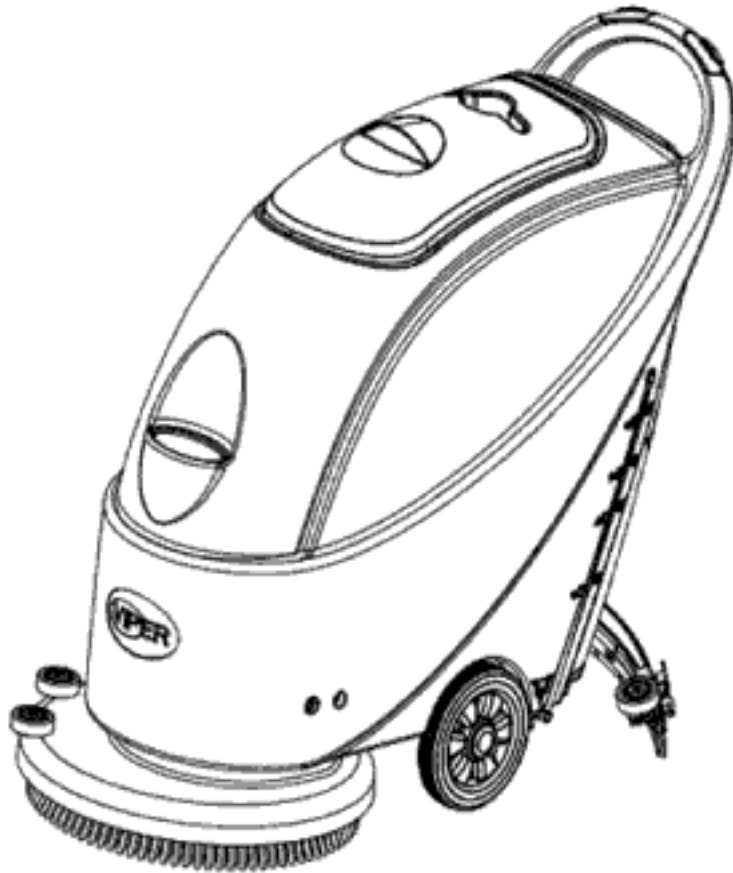

2017.10.12

TABLE OF CONTENTS

BATTERY VERSION - GENERAL VIEW	1
BATTERY VERSION - CONTROL SYSTEM AND ELECTRICAL SYSTEM	3
BATTERY VERSION - TANK SYSTEM	5
BATTERY VERSION - WHEELS AND SOLUTION SYSTEM	7
BATTERY VERSION - WIRING DIAGRAM	9
BATTERY VERSION - BRUSH SYSTEM	11
CABLE VERSION - GENERAL VIEW	13
CABLE VERSION - BRUSH SYSTEM	15
CABLE VERSION - CONTROL SYSTEM AND ELECTRICAL SYSTEM	17
CABLE VERSION - TANK SYSTEM	19
CABLE VERSION - WEAR AND TEAR PARTS	21
BATTERY VERSION - WEAR AND TEAR PARTS	23
CABLE VERSION - WHEELS AND SOLUTION SYSTEM	25
CABLE VERSION - WIRING DIAGRAM	27
BATTERY AND CABLE VERSION - SQUEEGEE SYSTEM	29

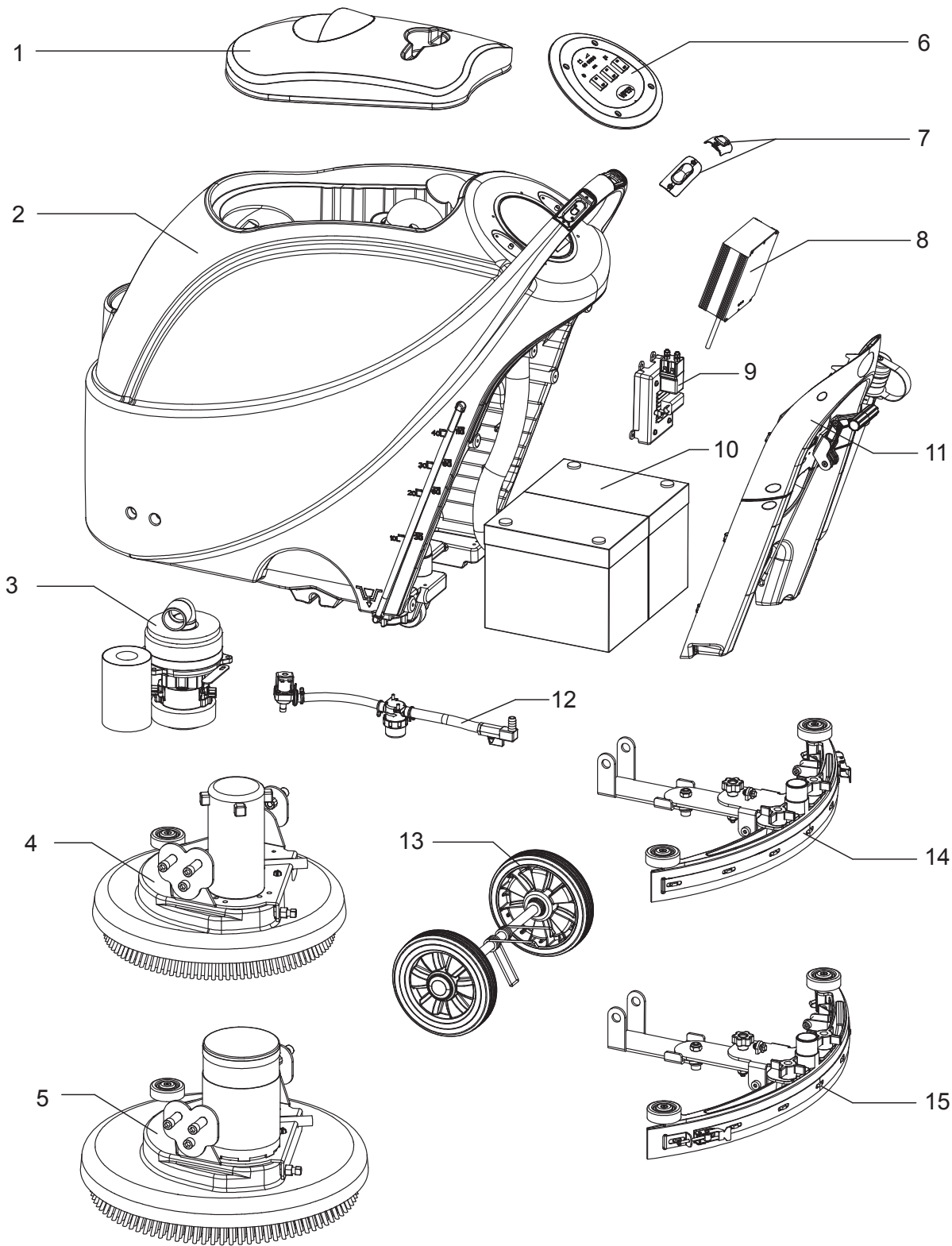

Pos.	Артикул	кол-во	Описание	Notes
1		1	COVER TANK ASSEMBLY	[1]
2		1	TANK ASSEMBLY	[1]
3		1	SUCTION PUMP SYSTEM	[1]
4A		1	17"BRUSH SYSTEM	[2]
5B		1	20"BRUSH SYSTEM	[2]
6		1	SWITCH PANEL ASSEMBLY	[3]
7		1	SAFETY SWITCH ASSEMBLY	
8		1	CHARGER	[3]
9		1	CONTROL PANEL BOARD	[3]
10		1	BATTERY ASSEMBLY	[1]
11		1	CONTROL PANEL SYSTEM	[3]
12		1	SOLUTION SYSTEM	[4]
13		1	WHEEL ASSEMBLY	[4]
14A		1	17"SQUEEGEE SYSTEM	[5]
15B		1	20"SQUEEGEE SYSTEM	[5]

Part Notes:

- [1] - See BATTERY VERSION - TANK SYSTEM
- [2] - See BATTERY VERSION - BRUSH SYSTEM
- [3] - See BATTERY VERSION - CONTROL SYSTEM AND ELECTRICAL SYSTEM
- [4] - See BATTERY VERSION - WHEELS AND SOLUTION SYSTEM
- [5] - See BATTERY AND CABLE VERSION - SQUEEGEE SYSTEM

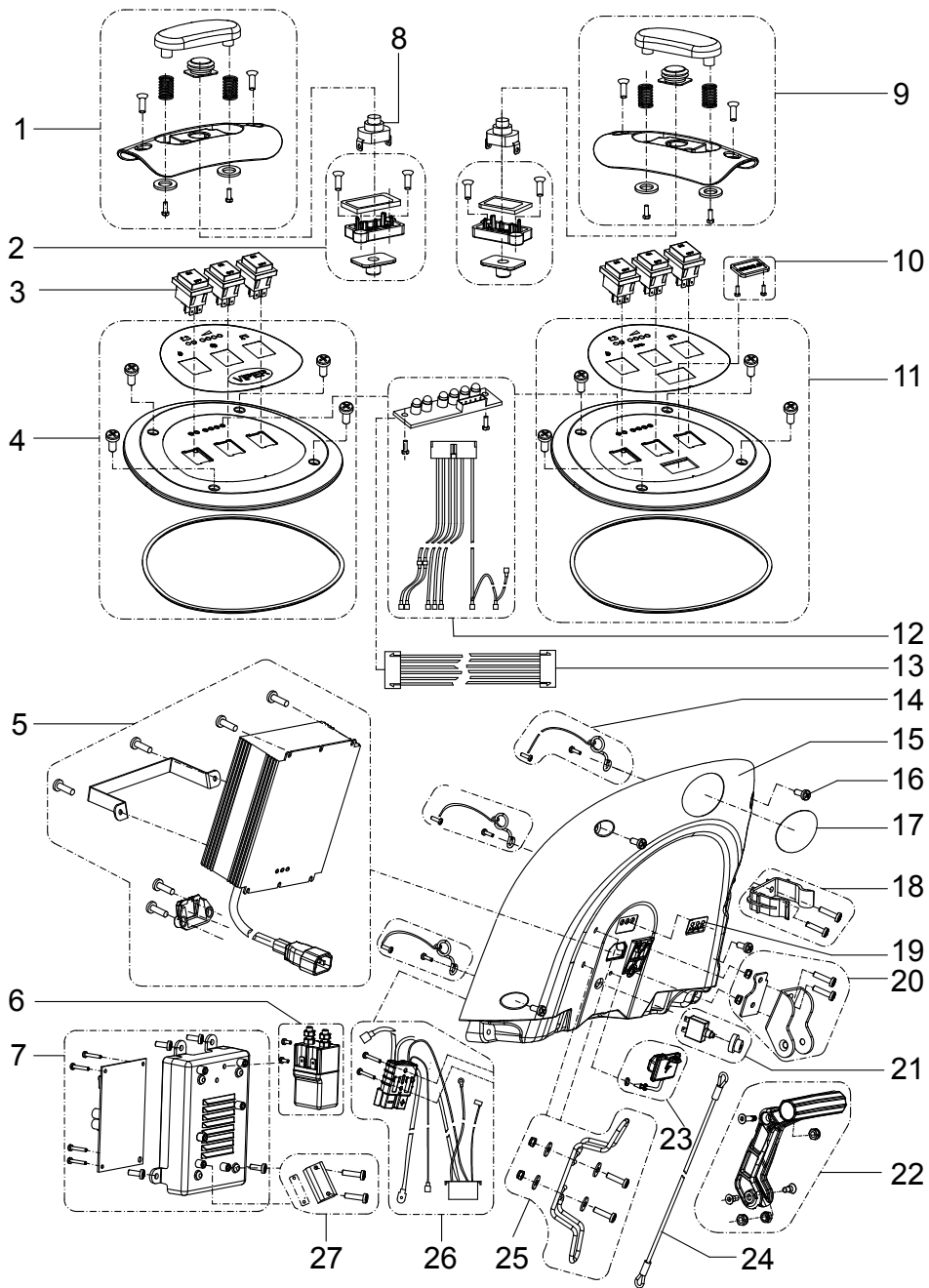

BATTERY VERSION - CONTROL SYSTEM AND ELECTRICAL SYSTEM

AS430

2015.05.19
2017.03.07

Pos.	Артикул	кол-во	Описание	Notes
1	VF90266	1	LEFT BUTTON SAFETY SWITCH KIT	
2	VF90268	2	MOUNTING FRAME SWITCH KIT	
3	VV60153	3	Выключатель электрический	
4A	VF90269	1	17 SWITCH COVER KIT	
5	VF90271-EU	1	Зарядное устройство	
5	VF90271-UK	1	CHARGER KIT UK VERSION	
6	VF90292	1	Эл.магнитный клапан	
7	VF90272	1	Панель управления электрическая	
8	VF90252	2	выключатель электрический	
9	VF90267	1	SAFETY SWITCH KNOB LEFT KIT	
10	VF90291	1	HOUR METER KIT	
11B	VF90270	1	20 SWITCH COVER KIT	
12A	VF90290	1	LED BOARD CONNENTER CABLE KIT	
12B	VF90290-1	1	LED BOARD CONNENTER CABLE KIT	
13	VF90238-3	1	CONTROL PANEL CONNENTER CABLE	
14	VF90274	3	NYLON CABLE HOOK KIT	
15	VF90205	1	COVER CONTROL HOUSING	
16	GT13054	4	SCREW PAN HEAD M5X12	
17A	VF90003-EU	1	17INCH SERIAL NUMBER LABEL	
17A	VF90003-UK	1	17INCH SERIAL LABEL	
17B	VF90007-EU	1	20INCH SERIAL NUMBER LABEL	
17B	VF90007-UK	1	20INCH SERIAL LABEL	
18	VF90275	1	CLAMP DRAIN HOSE KIT	
19	VF90004	1	LABEL BATTERY LEVEL	
20	VF90276	1	HAND BRACKET KIT	
21	VF90278	1	CIRCUIT BREAKER KIT	
22	VF90277	1	HANDLE LIFT KIT	
23	VF90279	1	POWER SAFETY COVER KIT	
24	VF90114	1	CABLE SQUEEGEE LIFT	
25	VF90280	1	CORD WRAP KIT	
26	VF90281	1	MAIN CABLE KIT	
27	VF90289	1	FUSE KIT	

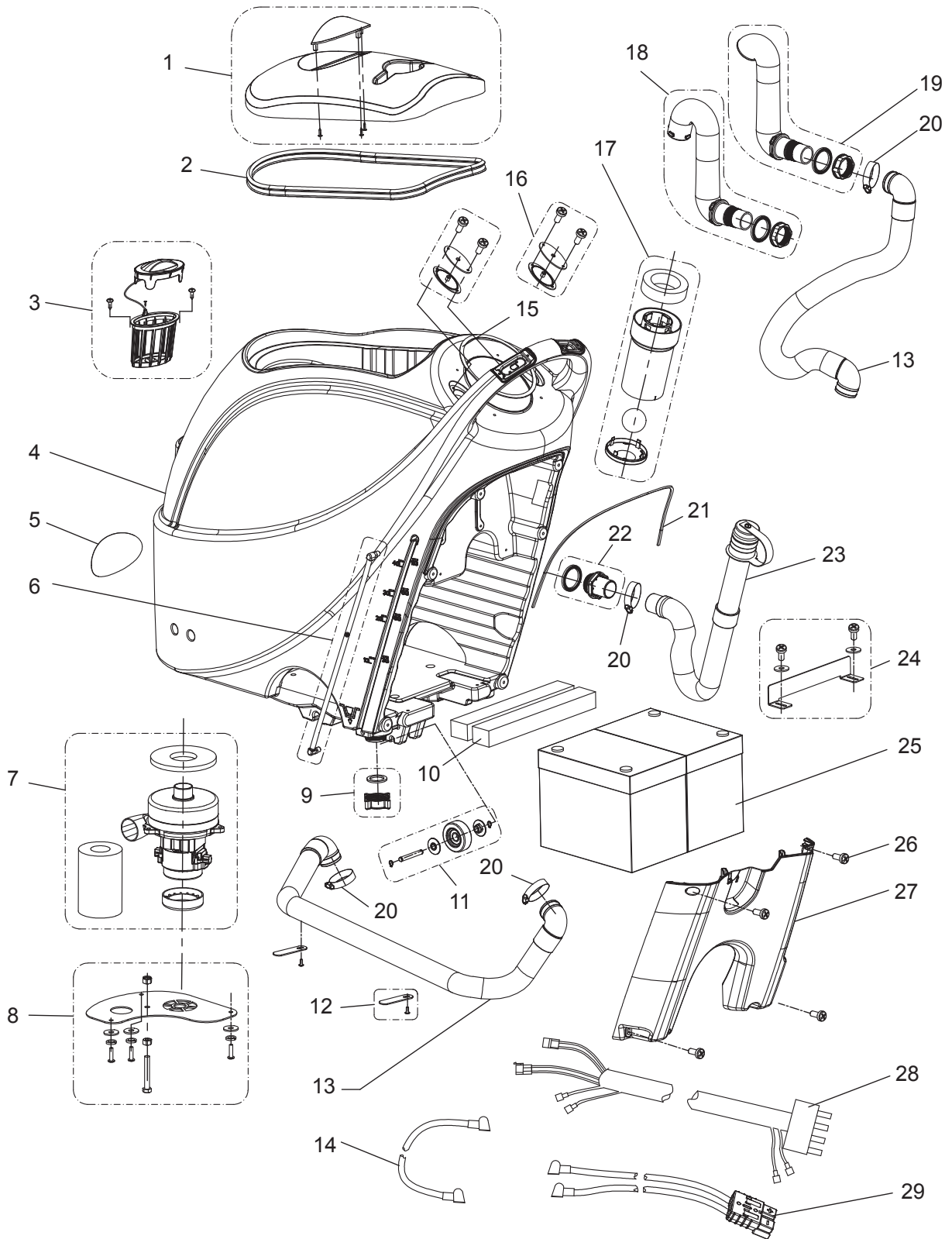

BATTERY VERSION - TANK SYSTEM

AS430

2015.05.19

2014.09.29

Pos.	Артикул	кол-во	Описание	Notes
1	VF90535	1	RECOVERY TANK KIT	
2	VF90504	1	GASKET	
3	VF90619	1	TANK FILTER NET KIT	
4	VF90501	1	TANK BATTERY VERSION	
5	VF90011	1	LOGO LABEL	
6	VF90622	1	WATER LEVEL INDICATION KIT	
7	VF90293	1	Насос вакуумный	
8	VF90264	1	COVER KIT VACUUM MOTOR	
9	VF90536	1	COVER KIT WATER OUTLET	
10	VF90533	2	BATTERY SPACER PANEL	
11	VF90312	1	2.5 WHEEL KIT	
12	VF90537	1	RETAINER PLATE KIT	
13	VF90508	2	SUCTION HOSE	
14	VF90246	1	BATTERY CABLE	
15	VF90231	1	GASKET	
16	VF90265	2	SEAL PLATE KIT	
17	VF90534	1	Поплавковый клапан AS430B	
18	VF90538	1	SUCTION TUBE CONNECTER KIT	
19	VF90539	1	DISCHARGE SEWAGE HOSE KIT	
20	VV10113	4	2 INCH CLAMP	
21	VF90218	1	CONTROL SEAL GASKET	
22	VF90446	1	DRAIN HOSE CONNECTER KIT	
23	VF90443	1	DRAIN HOSE-38	
24	VF90540	1	BATTERY BRACKET KIT	
26	GT13054	4	SCREW PAN HEAD M5X12	
27	VF90206	1	BATTERY COVER	
28	VF90254	1	WIRE HARNESS MOTOR	
29	VF90247	1	POWER CABLE	
25A	VF90223	2	Аккумуляторная батарея BATTERY 12V 85Ah/20h	
25B	VF90260	2	BATTERY 12V 105Ah/20h AGM	

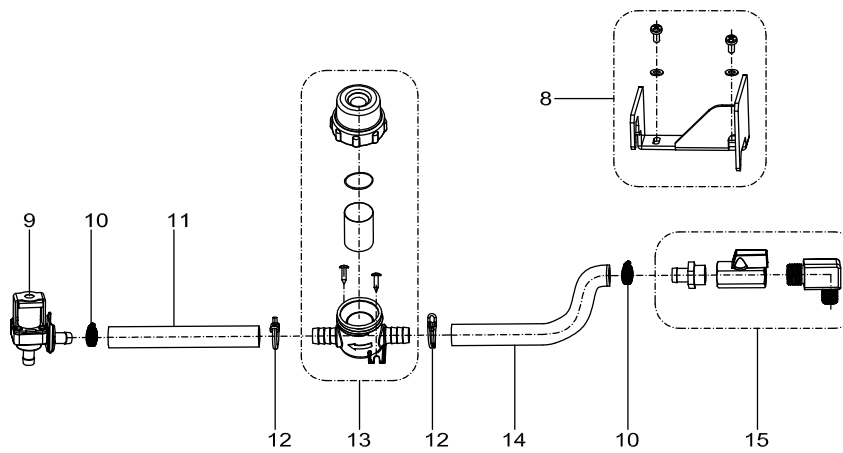
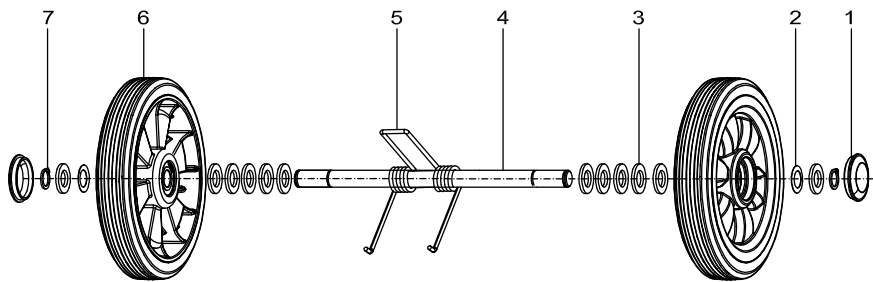

Pos.	Артикул	кол-во	Описание	Notes
1	VF89203	2	HUB CAP	
2	VF14563	2	WAVE WASHER	
3	VF14554	12	WASHER	
4	VF90304	1	WHEEL SHAFT	
5	VF82172	1	LOCK SPRING	
6	VF90305	2	Колесо 8"	
7	VF14552	2	RING D 17	
8	VF90623	1	SOLENOID VALVE BRACKET KIT	
9	VF90282	1	Соленоидный клапан компл.	[1]
10	VV10114	2	CLAMP	
11	VF90440	1	TUBING 260MM	
12	VF82148	2	CLAMP 16mm	
13	VF90621	1	Фильтр очистки воды	
14	VF90441	1	TUBING 160MM	
15	VF90624	1	Кран запорный шаровой со штуцерами	

Part Notes:

[1] - Battery version

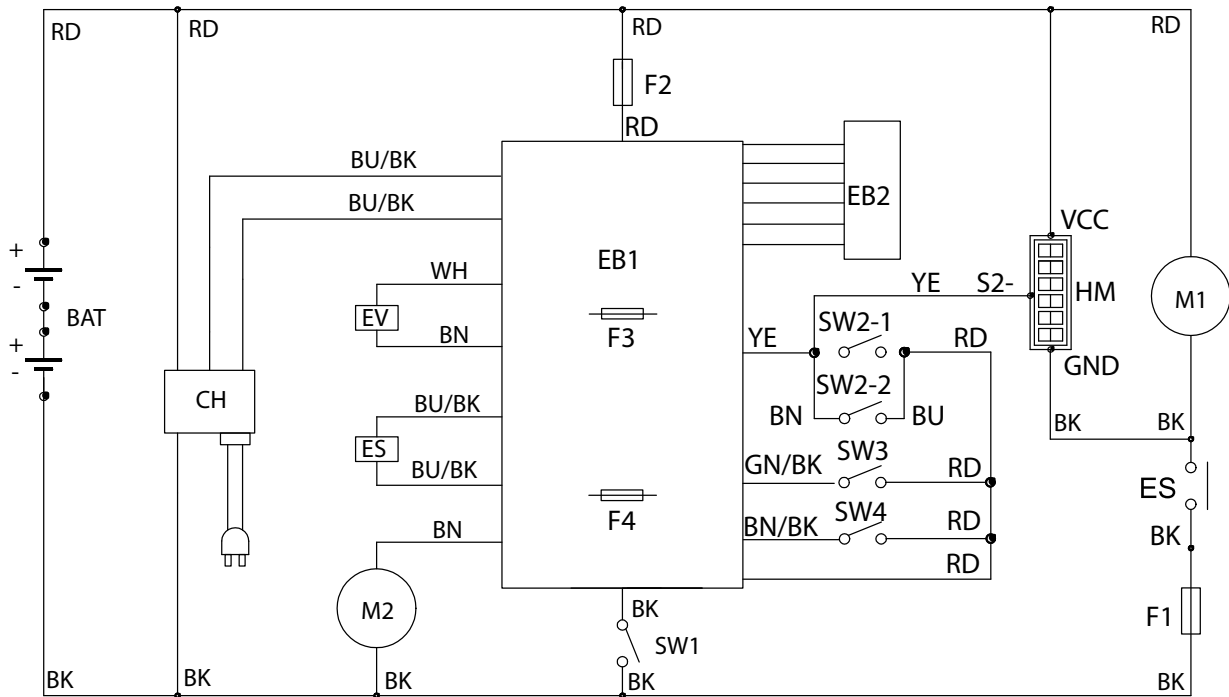

Pos.	Артикул	кол-во	Описание	Notes
BAT		1	Battery	
CH	VF90227-EU	1		
CH	VF90227-UK	1		
EB1	VF90238	1	PCB 17 CONTROL PANEL	
EB2	VF90238-2	1	LED INDICATOR BATTERY LEVEL	
ES	VF90230	1	Реле электрическое на напряю24в	
EV	VF90282	1	Соленоидный клапан компл.	
F1	VF90261	1	FUSE 40A	
F2	ZD48320	1	Щетки угол. комп. с загл.	
M1 A	VF90256EU	1	Мотор щетки 17'	
M1 B	VF90257EU	1	Мотор щетки 20'	
M2	VF90520	1	Вакуумный мотор	
SW1	VV60153	1	Выключатель электрический	
SW2	VF90252	1	выключатель электрический	
SW3	VV60153	1	Выключатель электрический	
SW4	VV60153	1	Выключатель электрический	
HM B	VF90287	1	HOUR METER	

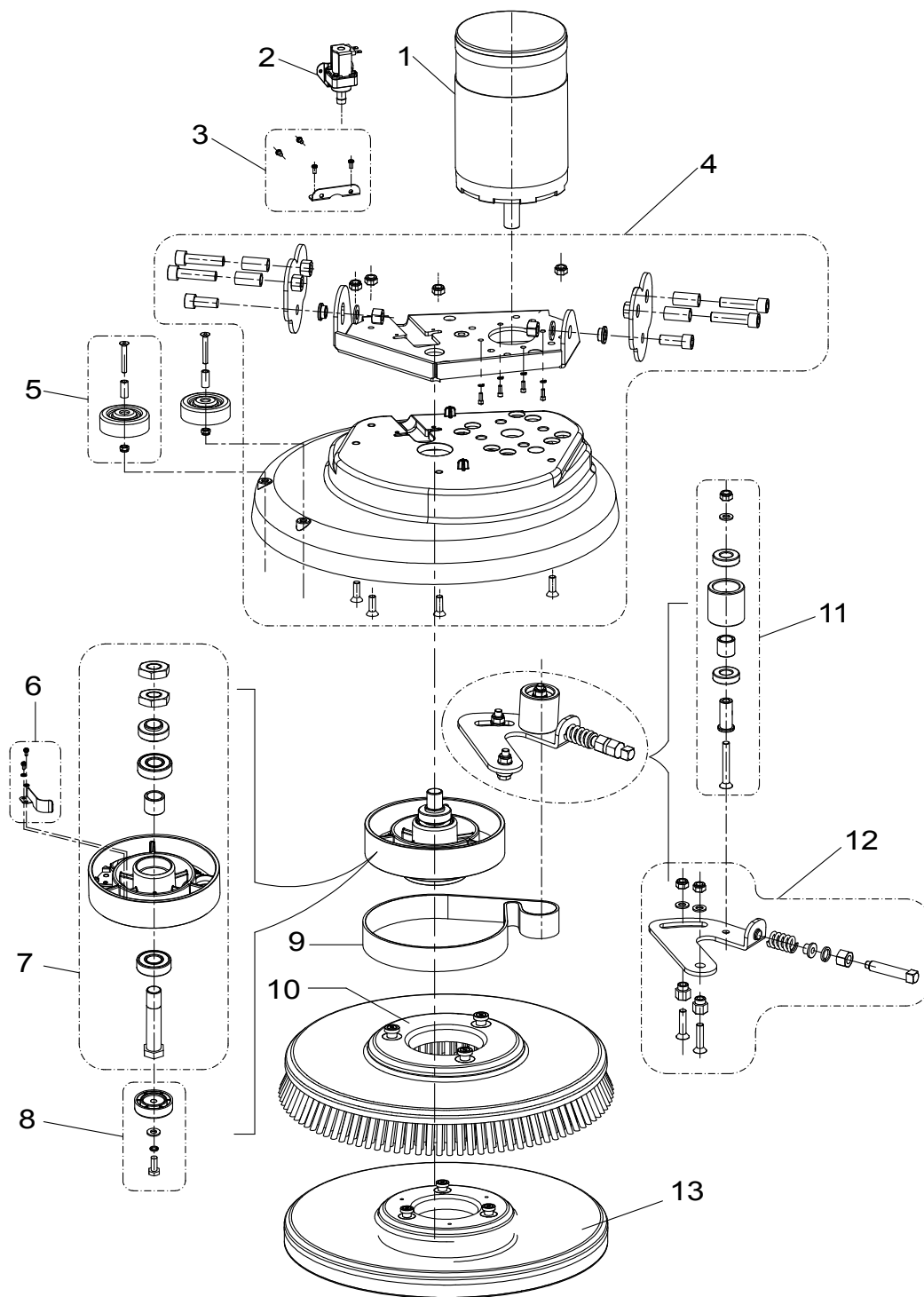

Pos.	Артикул	кол-во	Описание	Notes
1	VF90299	1	BRUSH MOTOR AS430-AS510 EU VERSION	[1]
1A	VF90256EU	1	Мотор щетки 17'	[2]
1B	VF90257EU	1	Мотор щетки 20'	[3]
2	VF90282	1	Соленоидный клапан компл.	
3	VF90447	1	SOLENOID VALVE BRACKET KIT	
4A	VF90448	1	Держатель 17' щетки компл.	[4]
4B	VF90449	1	Держатель 20' щетки компл.	[5]
5	VF90137	1	Ролики бампере компл.	
6	VF90450	1	BRUSH SPRING CLIP KIT	
7	VF90444	1	Вакуумный мотор	
8	VF90451	1	VIBRATION GASKET KIT	
9	VF90408	1	Ремень приводной	
10A	VF90411	1	Щетка 17'	[6]
10B	VF90417	1	Щетка 20'	[7]
11	VF90445	1	Натяжной ролик компл.	[8]
12	VF90452	1	Рычаг натяжн. ролика компл.	
13A	VF90428	1	Пэдодержатель 17'	[6]
13B	VF90416	1	Пэдодержатель 20'	[7]

Part Notes:

- [1] - after April/10/2017
TSB 2017-002 AS430B brush motor improvement
- [2] - A = Only for AS430B
TSB 2017-002 AS430B brush motor improvement
- [3] - B = Only for AS510B
TSB 2017-002 AS430B brush motor improvement
- [4] - A = Only for AS430B
- [5] - B = Only for AS510B
- [6] - A = Only for AS430B
TSB 2017-004 AS430 AS510 AS5160 bouncing and brush hub improvement
- [7] - B = Only for AS510B
TSB 2017-004 AS430 AS510 AS5160 bouncing and brush hub improvement
- [8] - TSB 2016-005 AS430 AS510 Belt tension pulley improvement

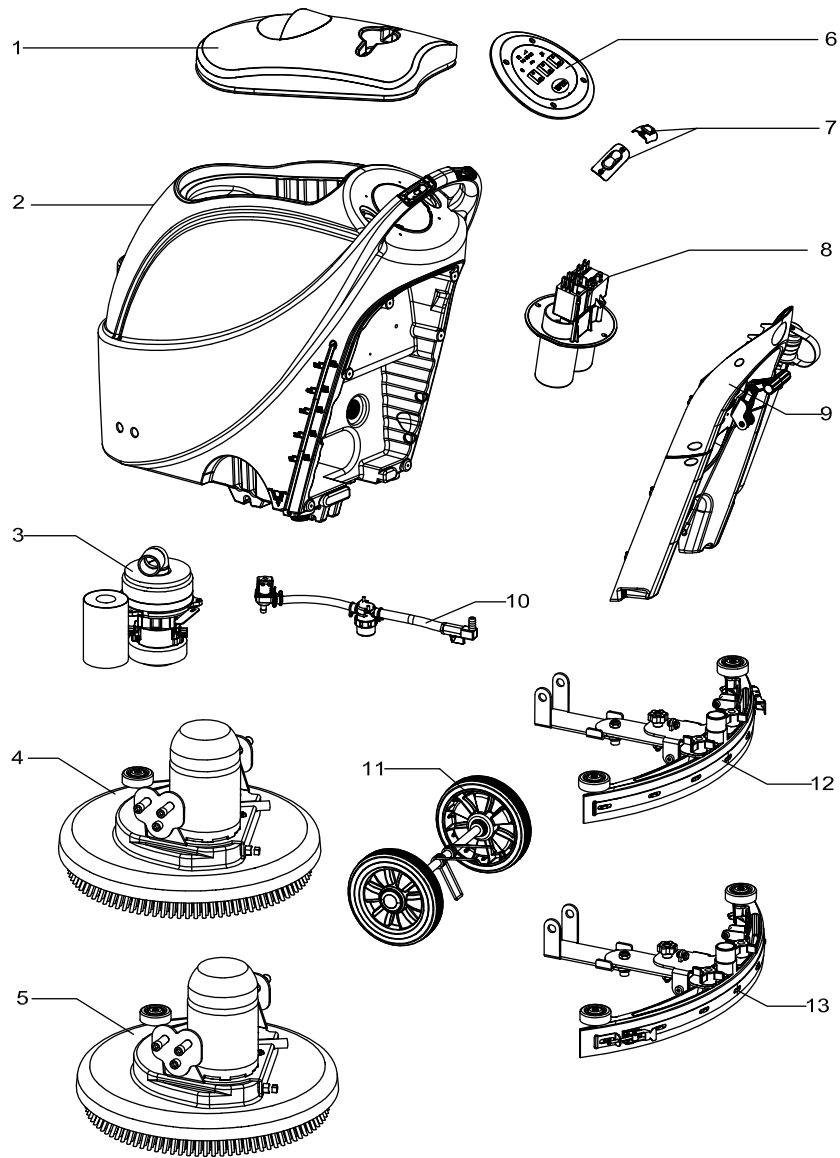

Pos.	Артикул	кол-во	Описание	Notes
1		1	COVER TANK ASSEMBLY	[1]
2		1	TANK ASSEMBLY	[1]
3		1	SUCTION PUMP SYSTEM	[1]
4B		1	20"BRUSH SYSTEM	[2]
5A		1	17"BRUSH SYSTEM	[2]
6		1	SWITCH PANEL ASSEMBLY	[3]
7		1	SAFETY SWITCH ASSEMBLY	
8		1	ELECTRON COMPONENT ASSEMBLY	[3]
9		1	CONTROL PANEL SYSTEM	[3]
10		1	SOLUTION SYSTEM	[4]
11		1	WHEEL ASSEMBY	[4]
12A		1	17"SQUEEGEE SYSTEM	[5]
13B		1	20"SQUEEGEE SYSTEM	[5]

Part Notes:

- [1] - See CABLE VERSION - TANK SYSTEM
- [2] - See CABLE VERSION - BRUSH SYSTEM
- [3] - See CABLE VERSION - CONTROL SYSTEM AND ELECTRICAL SYSTEM
- [4] - See CABLE VERSION - WHEELS AND SOLUTION SYSTEM
- [5] - See BATTERY AND CABLE VERSION - SQUEEGEE SYSTEM

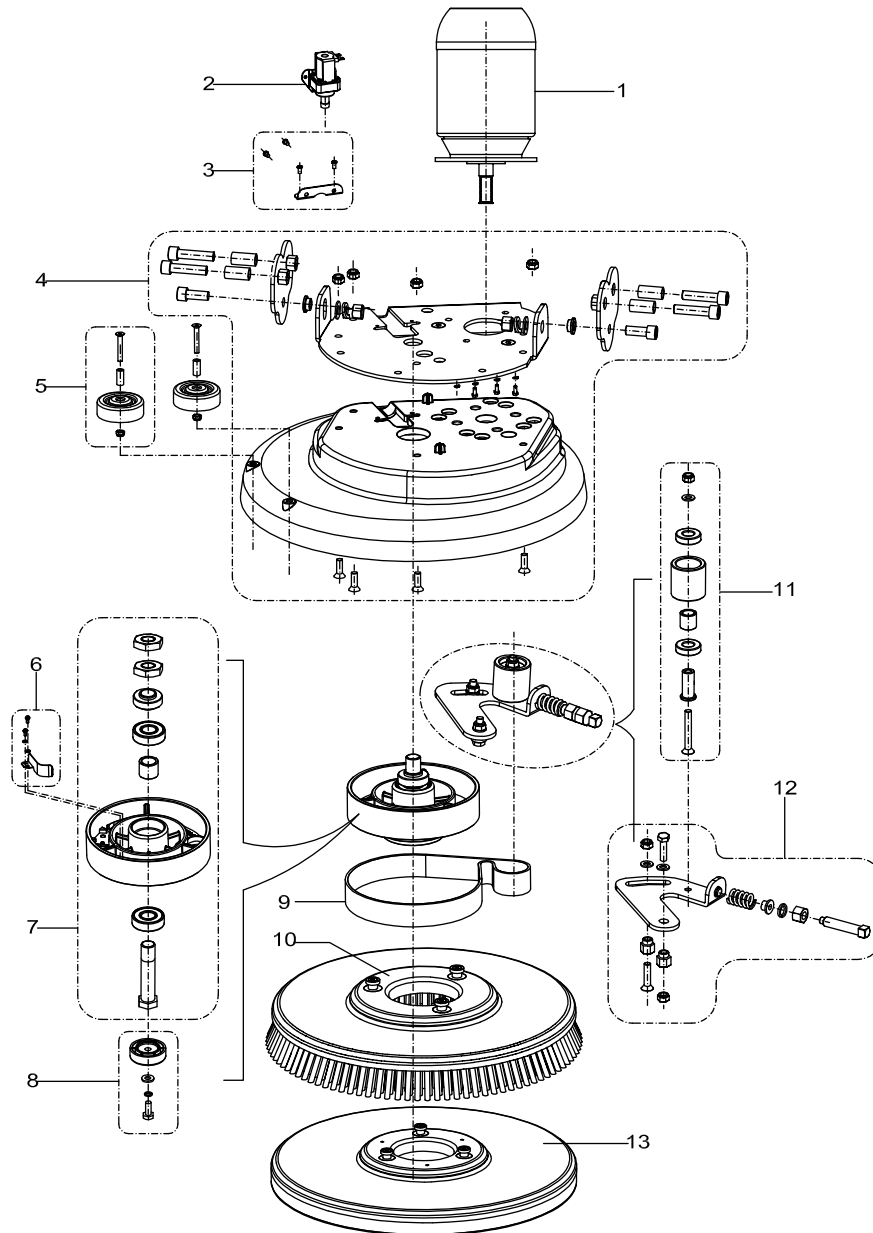

Pos.	Артикул	кол-во	Описание	Notes
1	VF90728	1	Мотор щетки компл.	
2	VF90283	1	Соленоидный клапан компл.	
3	VF90447	1	SOLENOID VALVE BRACKET KIT	
4A	VF90448	1	Держатель 17' щетки компл.	
4B	VF90449	1	Держатель 20' щетки компл.	
5	VF90137	1	Ролики бампера компл.	
6	VF90450	1	BRUSH SPRING CLIP KIT	
7	VF90465	1	DRIVEN PULLEY KIT WOLF1 CABLE VERSION	[1]
8	VF90451	1	VIBRATION GASKET KIT	
9	VF90462	1	BELT FOR WOLF1 CABLE VERSION	
10A	VF90411	1	Щетка 17'	[2]
10B	VF90417	1	Щетка 20'	[2]
11	VF90445	1	Натяжной ролик компл.	[3]
12	VF90452	1	Рычаг натяжн. ролика компл.	
13A	VF90428	1	Пэдодежатель 17'	[2]
13B	VF90416	1	Пэдодежатель 20'	[2]

Part Notes:

- [1] - GUARANTEE DATE EXPIRED
- [2] - TSB 2017-004 AS430 AS510 AS5160 bouncing and brush hub improvement
- [3] - TSB 2016-005 AS430 AS510 Belt tension pulley improvement

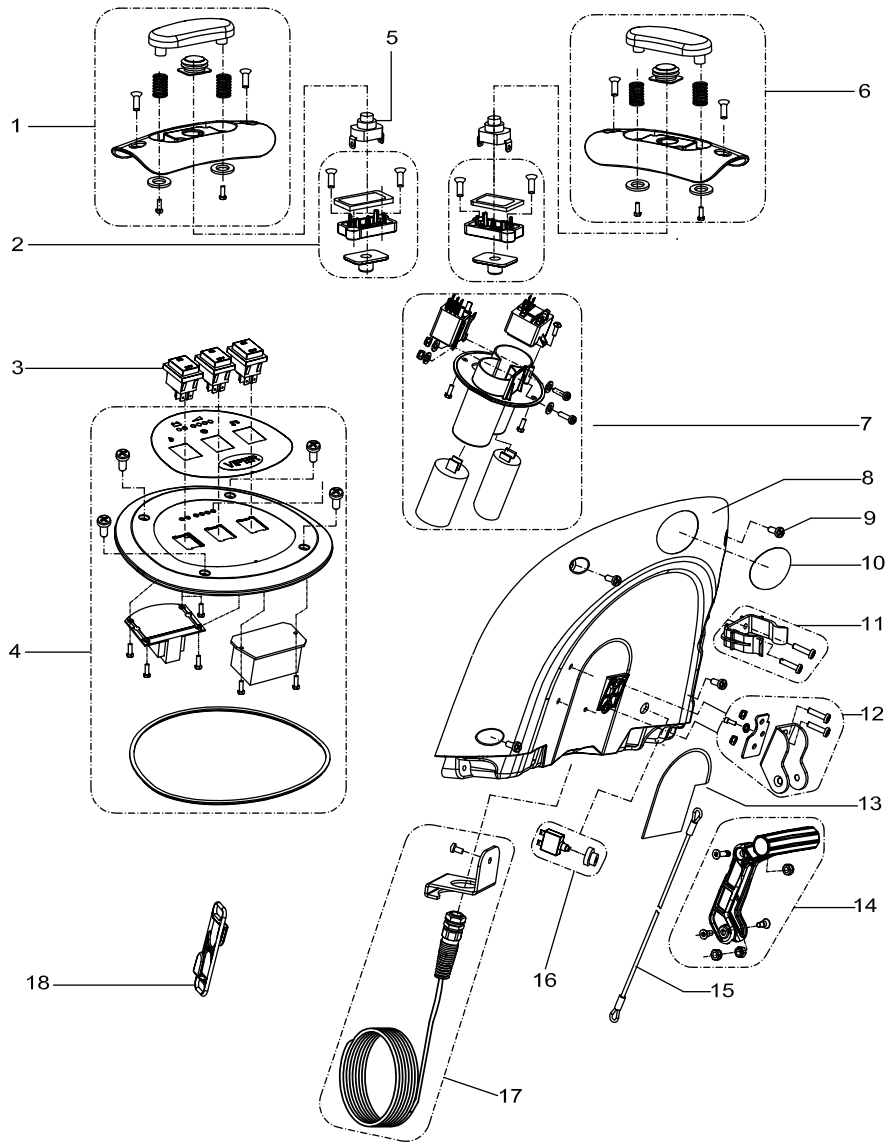

Pos.	Артикул	кол-во	Описание	Notes
1	VF90266	1	LEFT BUTTON SAFETY SWITCH KIT	
2	VF90268	2	MOUNTING FRAME SWITCH KIT	
3	VV60153	3	Выключатель электрический	
4	VF90805	1	SWITCH COVER KIT	
5	VF90252	2	выключатель электрический	
6	VF90267	1	SAFETY SWITCH KNOB LEFT KIT	
7	VF90806	1	Электроника компл.	
8	VF90205	1	COVER CONTROL HOUSING	
9	GT13054	4	SCREW PAN HEAD M5X12	
10A	VF90013-EU	1	SERIAL NUMBER LABEL FOR 17INCH EU	
10A	VF90013-UK	1	SERIAL NUMBER LABEL FOR 17INCH UK	
10B	VF90014-EU	1	SERIAL NUMBER LABEL FOR 20INCH EU	
10B	VF90014-UK	1	SERIAL NUMBER LABEL FOR 20INCH UK	
11	VF90275	1	CLAMP DRAIN HOSE KIT	
12	VF90276	1	HAND BRACKET KIT	
13	VF90010	1	DECAL BACK COVER	
14	VF90277	1	HANDLE LIFT KIT	
15	VF90114	1	CABLE SQUEEGEE LIFT	
16	VF90804	1	CIRCUIT BREAKER KIT	
17	VF90803EU	1	Кабель комп.	
17	VF90803UK	1	CABLE KIT	
18	VF422997	1	HANGING BOARD	

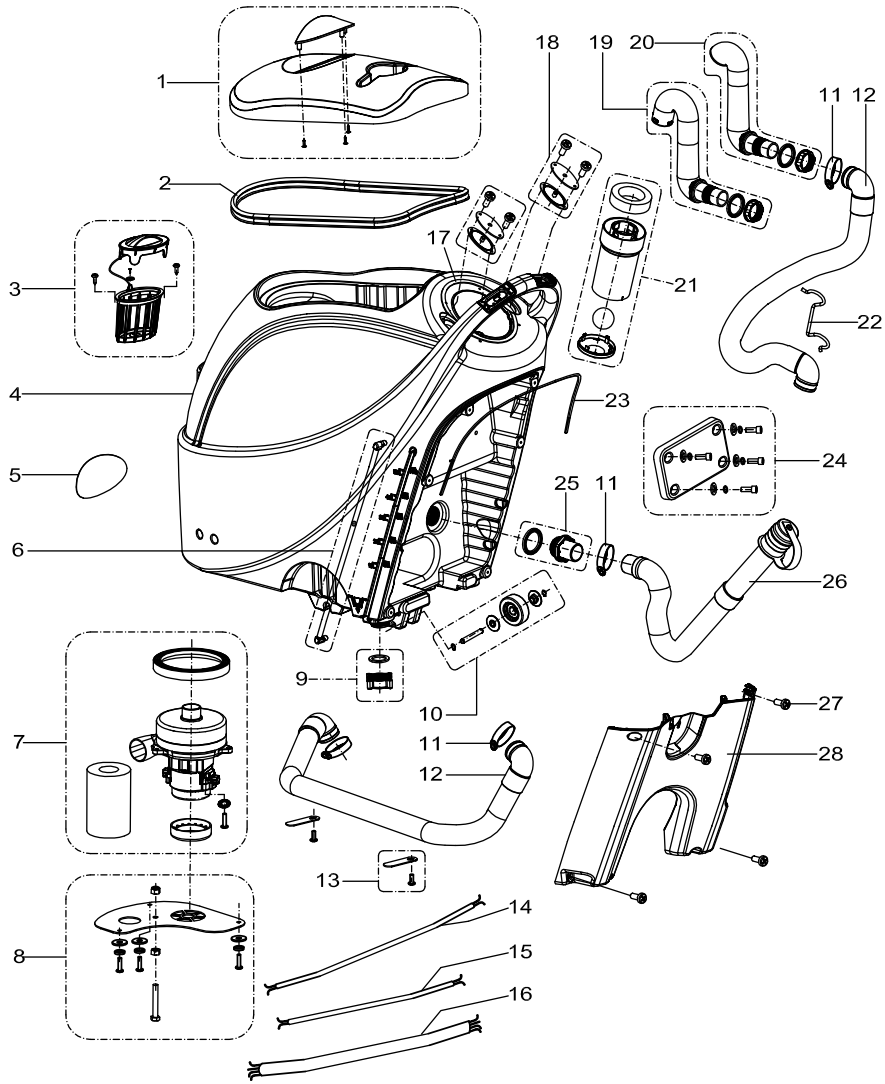

Pos.	Артикул	кол-во	Описание	Notes
1	VF90535	1	RECOVERY TANK KIT	
2	VF90504	1	GASKET	
3	VF90619	1	TANK FILTER NET KIT	
4	VF90519	1	TANK FOR CABLE VERSION	
5	VF90011	1	LOGO LABEL	
6	VF90622	1	WATER LEVEL INDICATION KIT	
7	VF90807	1	Вакуумный мотор	
8	VF90264	1	COVER KIT VACUUM MOTOR	
9	VF90536	1	COVER KIT WATER OUTLET	
10	VF90312	1	2.5 WHEEL KIT	
11	VA20304	4	CLAMP	
12	VF90508	2	SUCTION HOSE	
13	VF90537	1	RETAINER PLATE KIT	
14	VF90720	1	VACUUM MOTOR CONNECTION LINE	
15	VF90730	1	SOLENOID VALVE CONNECTION LINE	
16	VF90721	1	BRUSH MOTOR CONNECTION LINE	
17	VF90231	1	GASKET	
18	VF90265	2	SEAL PLATE KIT	
19	VF90538	1	SUCTION TUBE CONNECTER KIT	
20	VF90539	1	DISCHARGE SEWAGE HOSE KIT	
21	VF90534	1	Поплавковый клапан AS430B	
22	VF83150	1	Держатель стяжки	
23	VF90218	1	CONTROL SEAL GASKET	
24A	VF90801	1	WEIGHT KIT FOR 17INCH	
24B	VF90802	1	WEIGHT KIT FOR 20INCH	
25	VF90446	1	DRAIN HOSE CONNECTER KIT	
26	VF90443	1	DRAIN HOSE-38	
27	GT13054	4	SCREW PAN HEAD M5X12	
28	VF90206	1	BATTERY COVER	

Pos.	Артикул	кол-во	Описание	Notes
1	VF90504	1	GASKET	
2	VF90619	1	TANK FILTER NET KIT	
3	VF90293	1	Насос вакуумный	
4	VF90536	1	COVER KIT WATER OUTLET	
5	VF90312	1	2.5 WHEEL KIT	
6	VF90508	2	SUCTION HOSE	
7	VF90534	1	Поплавковый клапан AS430B	
8	VF90443	1	DRAIN HOSE-38	
9	VF90254	1	WIRE HARNESS MOTOR	
10	VF90247	1	POWER CABLE	
11	VV60153	3	Выключатель электрический	
12	VF90805	1	SWITCH COVER KIT	
13	VF90252	2	выключатель электрический	
14	VF90804	1	CIRCUIT BREAKER KIT	
15	VF90114	1	CABLE SQUEEGEE LIFT	
16	VF90305	2	Колесо 8'	
17	VF90283	1	Соленоидный клапан компл.	
18	VF90621	1	Фильтр очистки воды	
19	VF90624	1	Кран запорный шаровой со штуцерами	
20	VF90728	1	Мотор щетки комп.	
21	VF90137	1	Ролики бампере компл.	
22	VF90450	1	BRUSH SPRING CLIP KIT	
23	VF90465	1	DRIVEN PULLEY KIT WOLF1 CABLE VERSION	[1]
24	VF90462	1	BELT FOR WOLF1 CABLE VERSION	
25A	VF90411	1	Щетка 17'	
25B	VF90417	1	Щетка 20'	
26	VF90141	1	KONB ADJUSTMENT KIT	
27	VF81210	2	THUMB NUT	
28	VF90137	2	Ролики бампере компл.	
29	VF90136	2	Муфта в сб.	
30A	VF90103	1	Лезвие скребка перед. 17'	
30B	VF90119	1	Лезвие скребка перед. 20'	
31A	VF90104	1	Лезвие скребка зад. 17'	
31B	VF90120	1	Лезвие скребка зад. 20'	
32A	VF90428	1	Пэдодержатель 17'	
32B	VF90416	1	Пэдодержатель 20'	

Part Notes:

[1] - GUARANTEE DATE EXPIRED

Pos.	Артикул	кол-во	Описание	Notes
1	VF90504	1	GASKET	
2	VF90619	1	TANK FILTER NET KIT	
3	VF90293	1	Насос вакуумный	
4	VF90536	1	COVER KIT WATER OUTLET	
5	VF90312	1	2.5 WHEEL KIT	
6	VF90508	2	SUCTION HOSE	
7	VF90534	1	Поплавковый клапан AS430B	
8	VF90443	1	DRAIN HOSE-38	
9	VF90254	1	WIRE HARNESS MOTOR	
10	VF90247	1	POWER CABLE	
11	VV60153	3	Выключатель электрический	
12	VF90271-EU	1	Зарядное устройство	
13	VF90271-UK	1	CHARGER KIT UK VERSION	
14	VF90272	1	Панель управления электрическая	
15	VF90252	2	выключатель электрический	
16	VF90290	1	LED BOARD CONNENTER CABLE KIT	
17	VF90278	1	CIRCUIT BREAKER KIT	
18	VF90114	1	CABLE SQUEEGEE LIFT	
12	VF90281	1	MAIN CABLE KIT	
19	VF90289	1	FUSE KIT	
20	VF90305	2	Колесо 8'	
21	VF90282	1	Соленоидный клапан компл.	
22	VF90621	1	Фильтр очистки воды	
23	VF90624	1	Кран запорный шаровой со штуцерами	
24A	VF90256EU	1	Мотор щетки 17'	
24B	VF90257EU	1	Мотор щетки 20'	
25	VF90137	1	Ролики бампере компл.	
26	VF90450	1	BRUSH SPRING CLIP KIT	
27	VF90444	1	Вакуумный мотор	
28	VF90408	1	Ремень приводной	
29A	VF90411	1	Щетка 17'	
29B	VF90417	1	Щетка 20'	
30	VF90141	1	KONB ADJUSTMENT KIT	
31	VF81210	2	THUMB NUT	
32	VF90137	2	Ролики бампере компл.	
33	VF90136	2	Муфта в сб.	
34A	VF90103	1	Лезвие скребка перед. 17'	
34B	VF90119	1	Лезвие скребка перед. 20'	
35A	VF90104	1	Лезвие скребка зад. 17'	
35B	VF90120	1	Лезвие скребка зад. 20'	
13A	VF90428	1	Пэдодержатель 17'	
13B	VF90416	1	Пэдодержатель 20'	

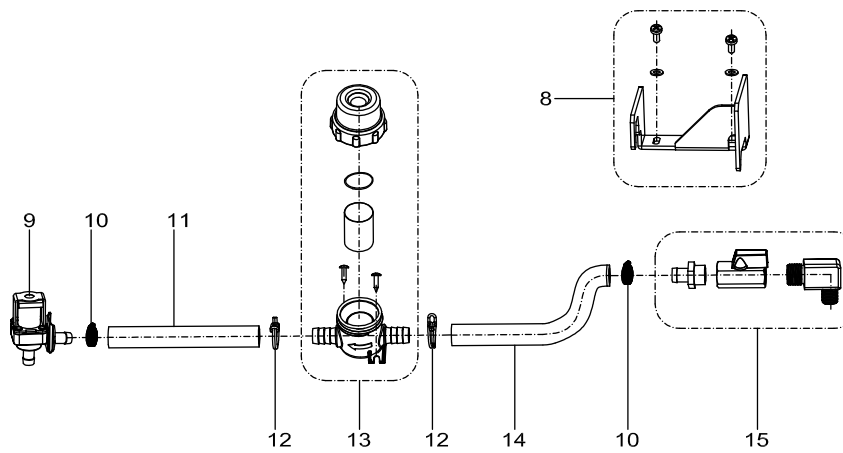
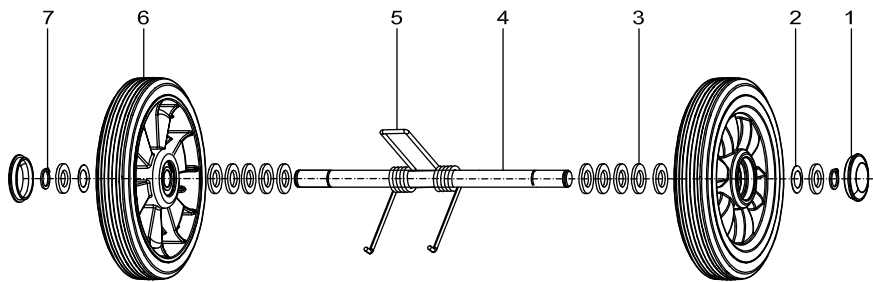

Pos.	Артикул	кол-во	Описание	Notes
1	VF89203	2	HUB CAP	
2	VF14563	2	WAVE WASHER	
3	VF14554	12	WASHER	
4	VF90304	1	WHEEL SHAFT	
5	VF82172	1	LOCK SPRING	
6	VF90305	2	Колесо 8"	
7	VF14552	2	RING D 17	
8	VF90623	1	SOLENOID VALVE BRACKET KIT	
9	VF90283	1	Соленоидный клапан компл.	[1]
10	VV10114	2	CLAMP	
11	VF90440	1	TUBING 260MM	
12	VF82148	2	CLAMP 16mm	
13	VF90621	1	Фильтр очистки воды	
14	VF90441	1	TUBING 160MM	
15	VF90624	1	Кран запорный шаровой со штуцерами	

Part Notes:

[1] - Cable version

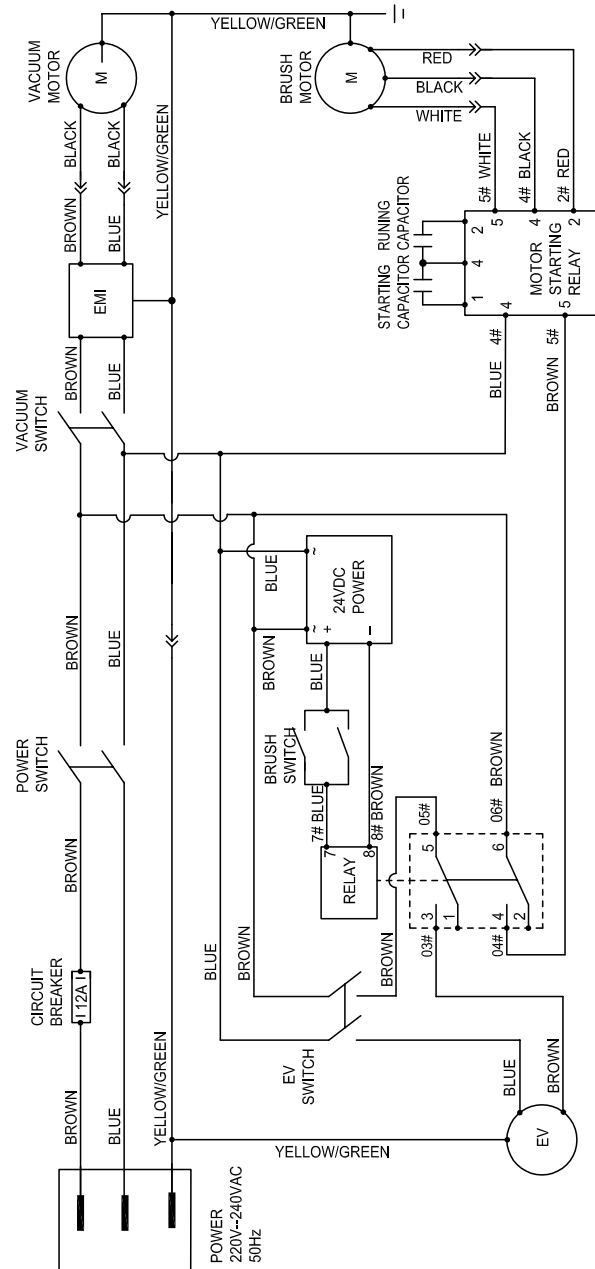

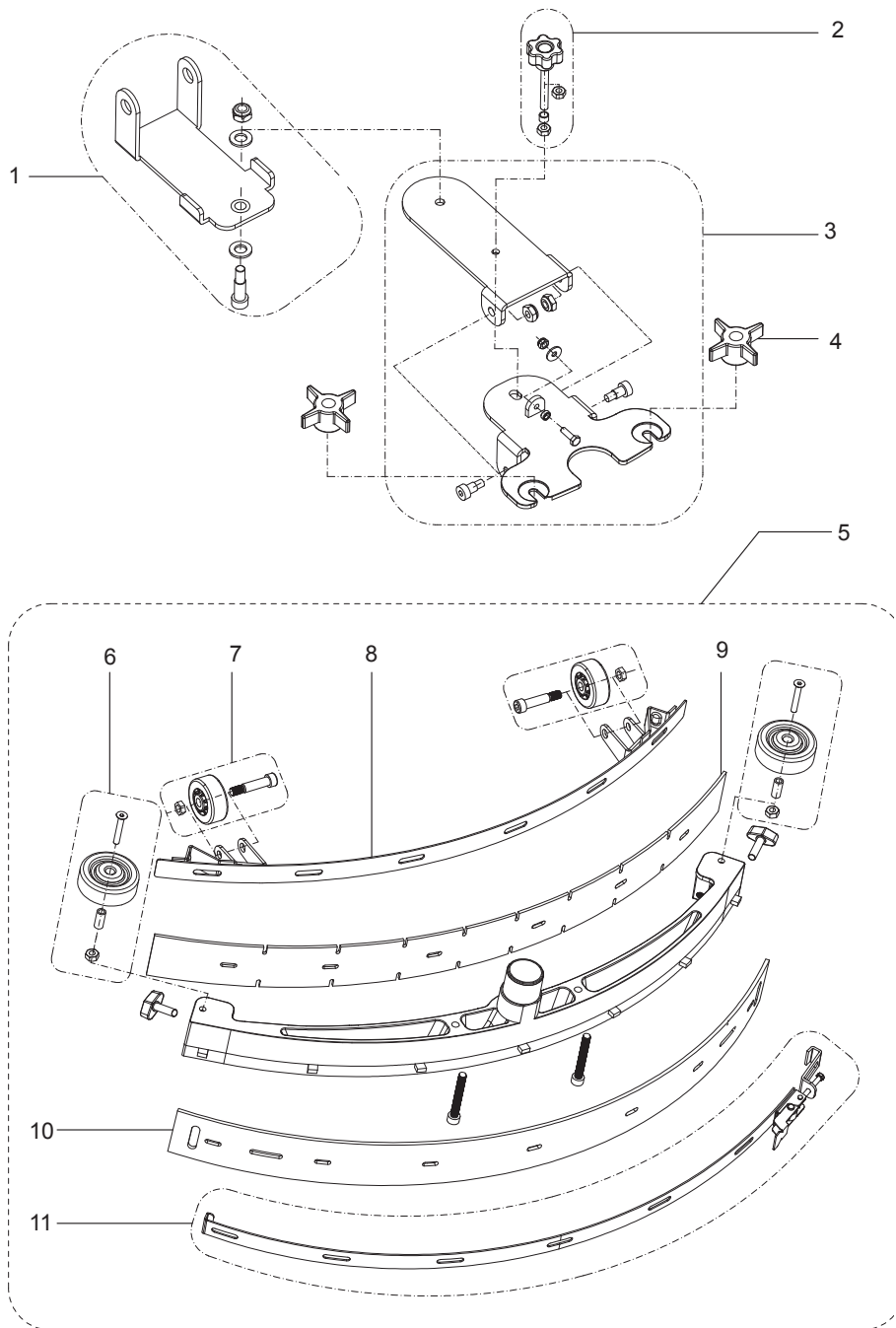

Pos.	Артикул	кол-во	Описание	Notes
1	VF90140	1	FRONT-SQUEEGEE-SUPPORT KIT	
2	VF90141	1	KONB ADJUSTMENT KIT	
3	VF90142	1	BACK-SQUEEGEE-SUPPORT KIT	
4	VF81210	2	THUMB NUT	
6	VF90137	2	Ролики бампере компл.	
7	VF90136	2	Муфта в сб.	
5A	VF90134	1	17 SQUEEGEE KIT	
5B	VF90135	1	20 SQUEEGEE KIT	
8A	VF90102	1	Пластина перед. скребка 17'	
8B	VF90118	1	Пластина перед. скребка 20'	
9A	VF90103	1	Лезвие скребка перед. 17'	
9B	VF90119	1	Лезвие скребка перед. 20'	
10A	VF90104	1	Лезвие скребка зад. 17'	
10B	VF90120	1	Лезвие скребка зад. 20'	
11A	VF90138	1	Пластина зад. скребка 17'	
11B	VF90139	1	Пластина зад. скребка 20'	

