

CHAMPION

Parts Manual

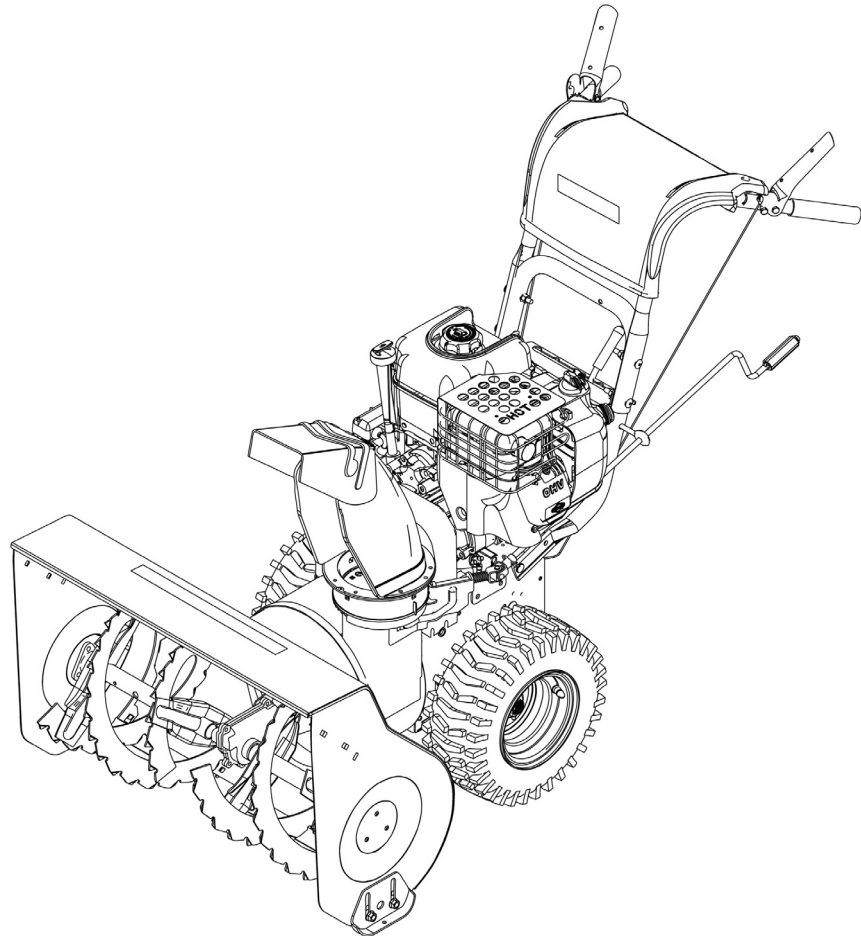

24" Dual Stage Snowthrower

Models

Mfg. No.	Description
1695951	Champion 9TP 24" Dual Stage Snowthrower, CE (2010)

Manual Part No. 1751215

Revision -

Rev. Date: 7/28/2010

PRODUCT COMPONENTS	PAGES
Handles & Controls Group	4
Engine Group	6
Auger Housing Group	8
Auger Drive Group	10
Traction Drive Group	12
Wheels & Tires Group	14
Decals Group	16
Gear Case Assembly	18
Discharge Chute Group	20
Torque Specification Chart	Inside Back Cover

Handles & Controls Group

REF NO	PART NO.	QTY.	DESCRIPTION
0010	1738089ZYP	1	PANEL, Dash
0030	1739782AYP	1	LEVER, Clutch, L.H.
0036	1750554YP	2	BOLT, Shoulder, 1/4 x 1-1/4
0050	1921962SM	2	CAPSCREW, Hex Head, 1/4-20 x 1-3/4, G5
0060	1920397SM	4	NUT, Hex Lock, ESNA Light, 1/4-20
0070	1927429SM	2	SCREW, Hex Washer Head, Taptite, 1/4-20 x 5/8
0090	1732471SM	1	CABLE & SPRING ASSEMBLY, Auger Drive, R.H.
0100	1739783AYP	1	LEVER, Clutch, R.H.
0110	1933896SM	2	NUT, Hex Lock, Nylon Insert, 10-24
0120	1726317SM	2	GRIP
0130	1736542YP	2	SPACER, Stepped
0140	1678392SM	2	SPACER, 1/4 ID x 3/8 OD x 5/16
0150	1734587ASM	1	HANDLE, Upper, R.H.
0160	1734586ASM	1	HANDLE, Upper, L.H.
0170	1960273SM	2	BOLT, Carriage, 5/16-18 x 2-1/4, G5
0180	1737274AYP	1	HANDLE, Lower
0190	1739305YP	4	NUT, Hex Flange, ESNA, 5/16-18
0200	1664847SM	2	SCREW, Hex-Washer head, Taptite, 5/16-18 x 3/4
0210	313441MA	1	BRACKET, Cable Adjusting
0220	308146MA	1	BOOT, Spring
0230	1502113MA	1	CABLE, Front Drive
0250	1931338SM	2	BOLT, Carriage, 5/16-18 x 1-3/4, G5
0310	581631E701MA	1	ROD, Shift
0320	302628MA	4	BOLT, Hex, 1/4-20 x 3/4, G5
0330	73826MA	4	NUT, Hex Centerlock, 1/4-20
0340	304438MA	1	GRIP, Lever
0360	760564MA	1	LEVER, Spring Shift
0370	1737760ZYP	1	BRACKET, Gear Select
0390	1921333SM	2	CAPSCREW, Hex Head, 5/16-18 x 1, G5
0400	1935048SM	2	NUT, Hex Flange, Two Way Lock, 5/16-18
0410	1931320SM	2	BOLT, Carriage, 1/4-20 x 1-1/4, G5
0430	1960556SM	4	SCREW, Pan Head Torx, 1/4-20 x 3/4
0460	71071MA	2	WASHER, Flat

Footnotes

The above parts group applies to the following Mfg. Nos.:

1695951 - Champion 9TP 24' Dual Stage Snowthrower

Engine Group

NOTE: Unless noted otherwise, use the standard hardware torque specification chart.

atalog_Data\MUR\Images\groups\2980000\2989367

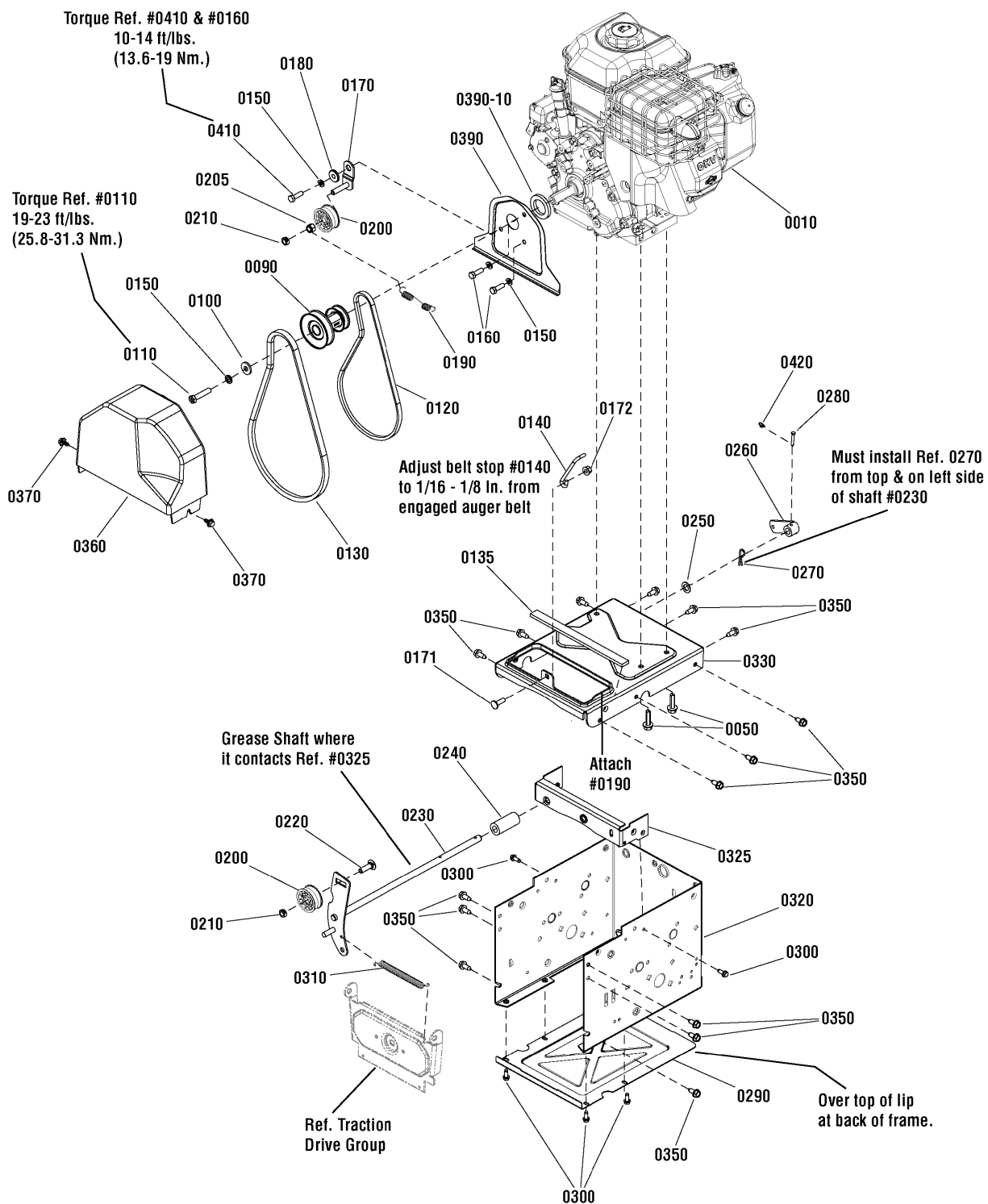

The above parts group applies to the following Mfg. Nos.:

1695951 - Champion 9TP 24" Dual Stage Snowthrower

Engine Group

REF NO	PART NO.	QTY.	DESCRIPTION
0010	12D116-0141-E8	1	* ENGINE, 9TP Briggs & Stratton (Engine Model: 12D116-0141-E8)
0050	75246GS	4	SCREW, Hex Head, Trilobular, 3/8-16 x 1-1/4
0090	1739514YP	1	PULLEY ASSEMBLY
0100	1919381SM	1	WASHER, 5/16
0110	910828MA	1	BOLT, Hex, 5/16-24 x 1
0120	1733324SM	1	V-BELT, Traction Drive, 3L 33.13
0130	585416MA	1	BELT, Auger, V4L 38.10 MF 05-10
0135	1750314YP	1	SEAL, Strip
0140	1737377YP	1	STOP, Belt
0150	1917356SM	4	LOCKWASHER, Spring
0160	1921515SM	2	CAPSCREW, Hex Head, 5/16-24 x 3/4, G5
0170	1739846YP	1	BRACKET, Idler
0171	1931335SM	1	BOLT, Carriage, 5/16-18 x 1, G5
0172	1739305YP	1	NUT, Hex Flange, ESNA, 5/16-18
0180	1501065MA	1	BUSHING, Idler Bracket
0190	165X164MA	1	SPRING, Extension, Idler
0200	1502120MA	2	IDLER, Plastic Ball Bearing
0205	7091299SM	1	NUT, Nylock, 3/8-16
0210	1960251SM	2	NUT, Hex Centerlock Jam, 3/8-16
0220	585781MA	1	BOLT, Carriage, 3/8-16 x 1-1/4, G5
0230	1739574YP	1	IDLER, Auger
0240	1739964YP	1	SPACER, Auger Bracket
0250	1960027SM	1	WASHER, 1/2
0260	1733451SM	1	ARM, Control
0270	0031X6MA	1	PIN, Hair
0280	1736381YP	1	PIN, Clevis
0290	1737221AYP	1	PANEL, Bottom
0300	1927429SM	12	SCREW, Hex Washer Head, Taptite, 1/4-20 x 5/8
0310	165X159MA	1	SPRING, Extension, Auger
0320	1739107ZP	1	FRAME BOX
0325	1739093AYP	1	BRACKET, Auger and Traction Rod Mount
0330	1739450ZYP	1	PLATE, Engine
0350	1664847SM	19	CAPSCREW, Hex Washer Head, Taptite, 5/16-18 x 3/4
0360	1750551YP	1	COVER, Belt
0370	26X306MA	2	SCREW, Hex Washer Head, 1/4 x 3/4
0390	1733868ASM	1	WATER SHIELD
0390-10	1733898SM	1	SEAL, Foam
0410	910828MA	1	BOLT, Hex, 5/16-24 x 1
0420	7023590SM	1	PIN, Cotter, 1/4

Footnotes

Note* See your local Briggs & Stratton distributor for parts and service.

The above parts group applies to the following Mfg. Nos.:

1695951 - Champion 9TP 24" Dual Stage Snowthrower

Auger Housing Group

NOTE: Unless noted otherwise,
use the standard hardware torque
specification chart.

atalog_Data\MUR\Images\groups\2980000\2989300

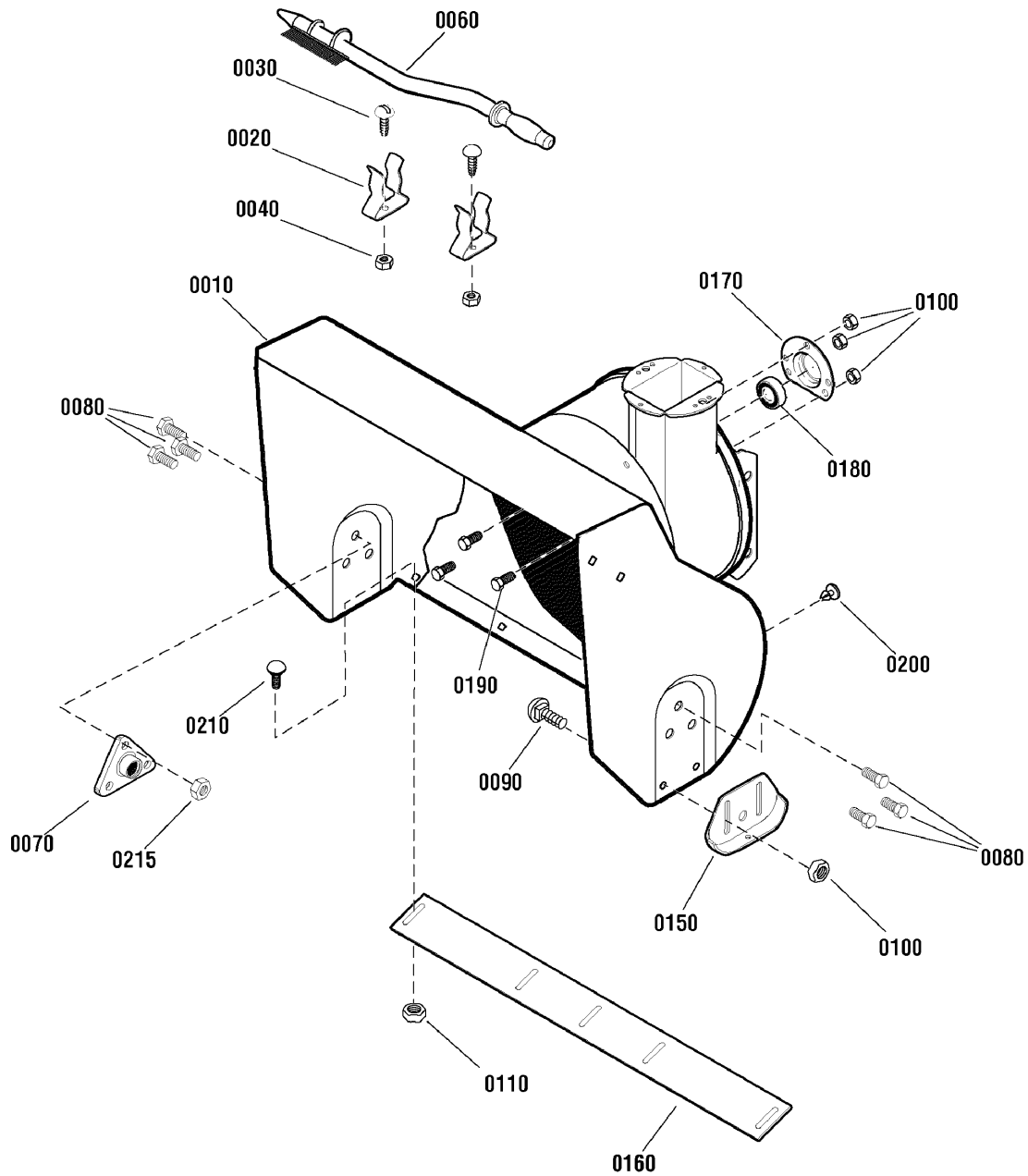

The above parts group applies to the following Mfg. Nos.:

1695951 - Champion 9TP 24" Dual Stage Snowthrower

Auger Housing Group

REF NO	PART NO.	QTY.	DESCRIPTION
0010	1751196ZYP	1	AUGER HOUSING
0020	1736620YP	2	CLAMP, Spring
0030	1960569SM	2	SCREW, Truss Head, Torx #10-24 x 3/8
0040	15X146MA	2	NUT, Hex Lock, Nylon, #10C
0060	1736094YP	1	BRUSH, Cleanout
0070	9517MA	2	BEARING, Auger
0080	9357MA	6	CAPSCREW, 5/16-18 x 3/4
0090	7091547YP	4	BOLT, Carriage, 3/8-16 X 3/4, G5
0100	7091619SM	4	NUT, Hex Flange, 3/8-16
0110	710026MA	7	NUT, Hex Flange, Serrated Lock, 5/16-18
0150	1737986AYP	2	SKID, Height Adjust
0160	1738335AYP	1	BLADE, Scraper
0170	582957YZMA	1	RETAINER, Ball Bearing
0180	1705897SM	1	BEARING, Ball
0190	001X45MA	3	CAPSCREW, Hex Head, 5/16-18 x 5/8
0200	760040MA	2	PLUG
0210	7090799SM	4	BOLT, Carriage, 5/16-18 x 5/8, G5
0215	711862MA	6	NUT, Hex Flange, Top Lock, 5/16-18

Footnotes

The above parts group applies to the following Mfg. Nos.:

1695951 - Champion 9TP 24" Dual Stage Snowthrower

Auger Drive Group

NOTE: Unless noted otherwise,
use the standard hardware torque
specification chart.

atalog_Data\MUR\Images\groups\2980000\2989301

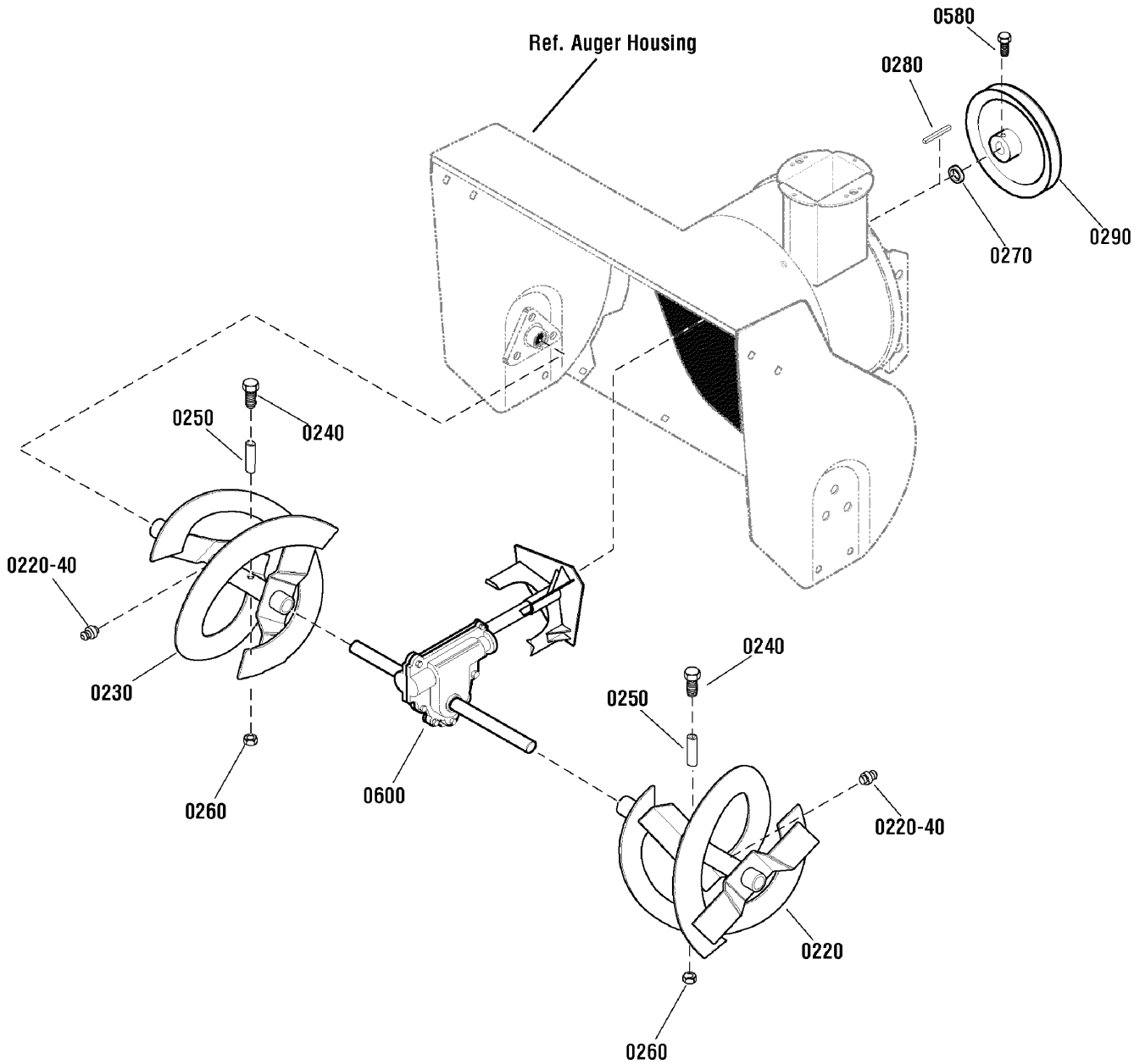

The above parts group applies to the following Mfg. Nos.:

1695951 - Champion 9TP 24" Dual Stage Snowthrower

Auger Drive Group

REF NO	PART NO.	QTY.	DESCRIPTION
0220	1750036BCYP	1	AUGER, L.H. (Includes Ref. No. 0220-40)
0230	1750037BCYP	1	AUGER, R.H. (Includes Ref. No. 0220-40)
0220-40	10104MA	1	FITTING, Zerk
0240	9524MA	2	CAPSCREW, Hex Head, 1/4-20 x 1-1-3/4, G2
0250	3943MA	2	SPACER, Sleeve, 1/4 x 1/2
0260	73826MA	2	NUT, Hex Centerlock, 1/4-20
0270	1501158MA	1	SPACER, Friction Pulley
0280	2001022MA	1	KEY, Square 3/16 x 3/4
0290	1501211MA	1	PULLEY, V4L 6.12 x .67
0580	577400MA	2	CAPSCREW, Hex Head, 5/16-18 x 5/8
0600	1738602YP	1	GEAR CASE ASSEMBLY, Complete
--	1501216MA	1	SHEAR BOLT KIT (Includes Ref. Nos. 0240, 0250 & 0260)

Footnotes

The above parts group applies to the following Mfg. Nos.:

1695951 - Champion 9TP 24" Dual Stage Snowthrower

Traction Drive Group

REF NO	PART NO.	QTY.	DESCRIPTION
0200	579851MA	1	CHAIN, Roller, #420 x 19.00
0210	334163MA	4	BEARING AND RETAINER ASSEMBLY
0220	579858MA	5	WASHER, Flat, 1/2
0230	1924856SM	8	SCREW, Hex Washer Head Taptite, 5/16-18 x 1/2
0240	579868MA	1	CHAIN, ROLLER #420 X 18.00 LG
0250	11X30MA	5	RETAINER, Ring, 7/16
0260	1502105YZMA	1	SPRING LINK ASSEMBLY
0300	1736469YP	3	SPRING, Extension
0310	1501090MA	1	SPROCKET, Set
0320	1960027SM	2	WASHER, 1/2
0330	1501092YZMA	1	AXLE, Swing Plate
0340	1501562YZMA	1	AXLE, 3/4 Dia. x 21-5/16
0350	01X193MA	1	SCREW, 1/4 - 20 x 1-3/4
0420	1501089MA	1	SPROCKET, Axle
0430	1501114MA	2	BEARING, Axle
0440	1501100MA	1	HEX SHAFT & SPROCKET ASSEMBLY
0450	337029MA	1	HUB, Friction Wheel & Bearing
0460	1501435MA	1	WHEEL, Friction Disc
0500	1921959SM	3	CAPSCREW, Hex Head 1/4-20 x 5/8 G5
0510	1928372SM	3	NUT, Hex KEPS 1/4-20
0520	1733326SM	1	RING, Retaining Extension
0530	15X114MA	1	NUT, Flange Lock, 3/8-24
0540	1501057YZMA	1	PLATE, Swinging
0550	1501158MA	1	SPACER, Friction Pulley
0560	1501115MA	1	FRICTION PULLEY ASSEMBLY
0600	1501085YZMA	1	ASSEMBLY, Speed Selector
0610	579944MA	1	BEARING, Flange
0620	1920397SM	2	NUT, Hex Lock ESNA Light 1/4-20
0630	1922837SM	1	CAPSCREW, Hex Head, 1/4-20 x 1-1/2 G5
0640	579860MA	1	SPOOL CABLE, Auger Control
0650	1750398YP	1	BRACKET, Cable Spool
0660	1750403YP	1	CABLE, Front Drive
0680	001X38MA	2	CAPSCREW, Hex Head, 1/4-20 x 5/8
0690	7091576SM	2	NUT, Hex, 1/4-20, G5
0700	1916964SM	2	LOCKWASHER, Spring, 1/4
0710	1502030YZMA	1	BRACKET, Support
0720	1927429SM	2	CAPSCREW, Hex Washer Head, Taptite, 1/4-20 x 5/8

Footnotes

The above parts group applies to the following Mfg. Nos.:

1695951 - Champion 9TP 24' Dual Stage Snowthrower

Wheels & Tires Group

NOTE: Unless noted otherwise,
use the standard hardware torque
specification chart.

atalog_Data\MUR\Images\groups\2980000\2989408

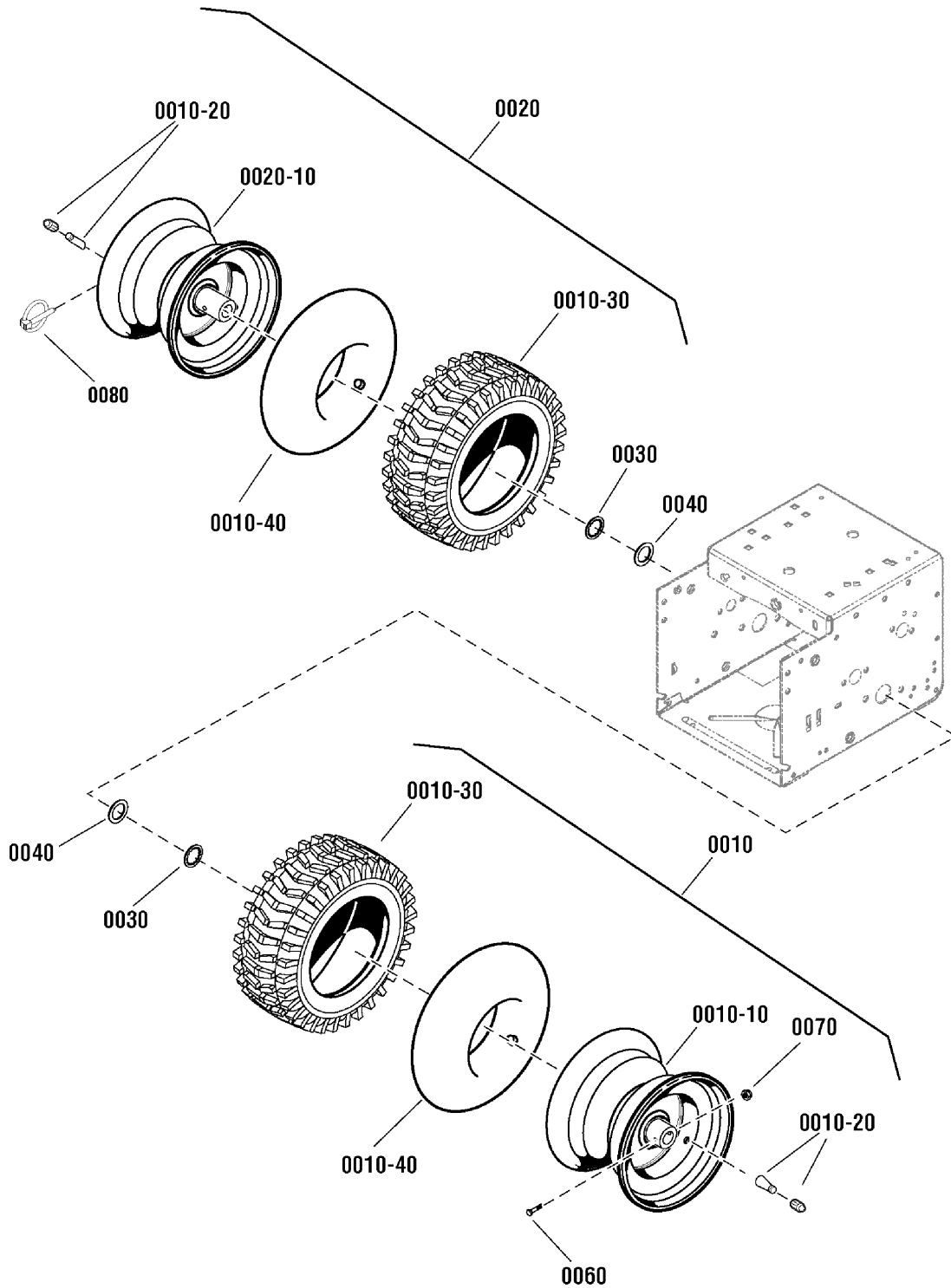

The above parts group applies to the following Mfg. Nos.:

1695951 - Champion 9TP 24" Dual Stage Snowthrower

Wheels & Tires Group

REF NO	PART NO.	QTY.	DESCRIPTION
0010	1751285YP	1	WHEEL & TIRE ASSEMBLY, LH (Includes Ref. Nos. 0010-10, 0010-20, 0010-30 & 0010-40)
0010-10	-----	1	* WHEEL, Rim, LH
0010-20	2172353SM	2	VALVE STEM & CAP
0010-30	1751295YP	2	TIRE, 2 Ply, 13 x 5-6
0010-40	2164247SM	2	TUBE, Tire
0020	1751286YP	1	WHEEL & TIRE ASSEMBLY, RH (Includes Ref. Nos. 0020-10, 0010-20, 0010-30 & 0010-40)
0020-10	-----	1	* WHEEL, Rim, RH
0030	1657528SM	2	RING, Retaining
0040	712120MA	2	WASHER, Flat, 3/4
0060	577015MA	1	BOLT, Hex, 1/4-20 x 1-3/4, G5
0070	15X145MA	1	NUT, Hex Nylock, 1/4-20
0080	73842MA	1	PIN, Klik

Footnotes

* Not a servicable part. Order complete wheel and tire assembly.

The above parts group applies to the following Mfg. Nos.:

1695951 - Champion 9TP 24" Dual Stage Snowthrower

Decals Group

**NOTE: Unless noted otherwise,
use the standard hardware torque
specification chart.**

atalog_Data\MUR\Images\groups\2980000\2989373

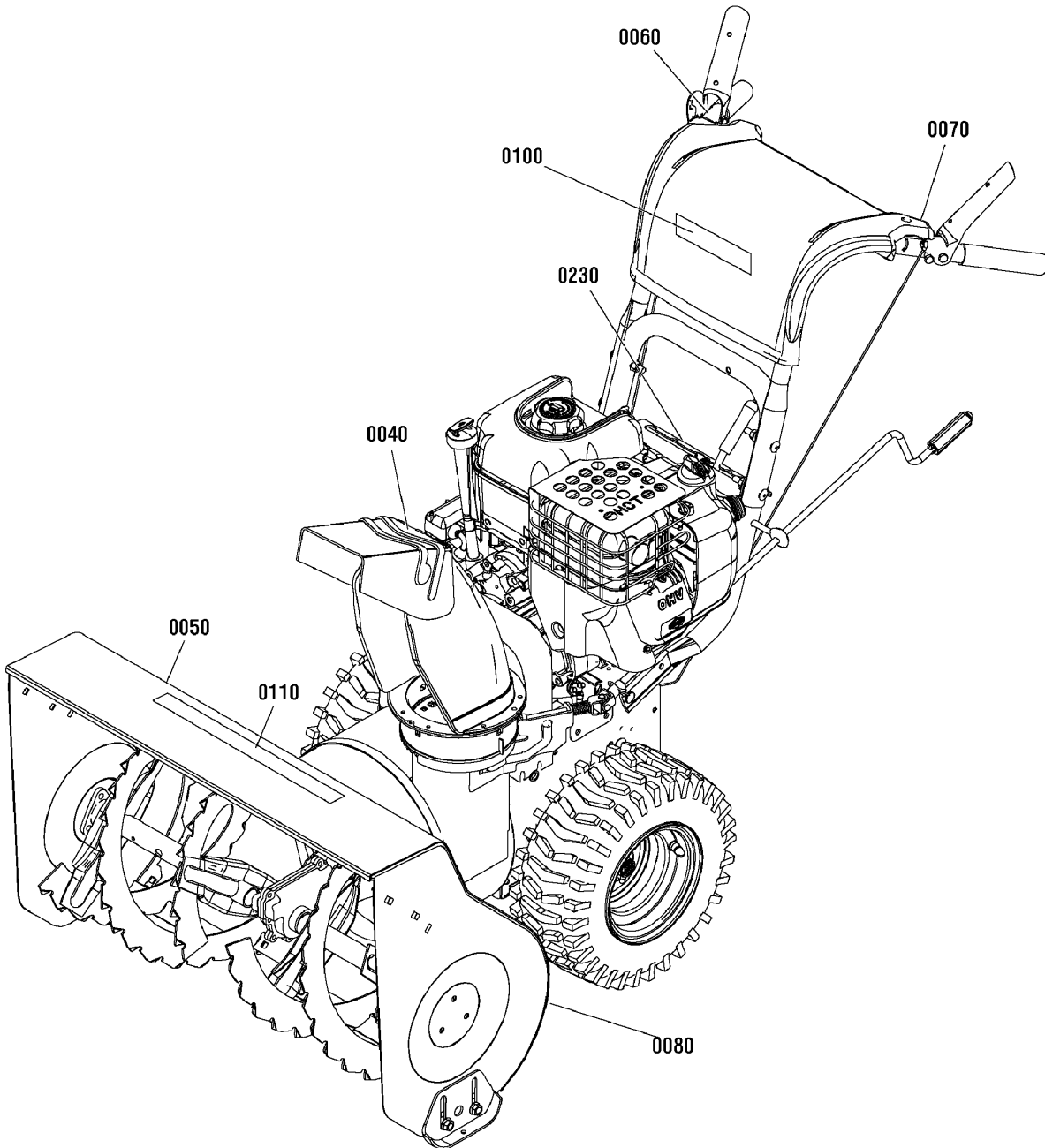

The above parts group applies to the following Mfg. Nos.:

1695951 - Champion 9TP 24' Dual Stage Snowthrower

Decals Group

REF NO	PART NO.	QTY.	DESCRIPTION
0040	1727207SM	1	DECAL, Chute Warning, Export
0050	1737867YP	1	DECAL, Danger Auger Icons, Export
0060	1737869YP	1	DECAL, Auger Control Symbols
0070	1737870YP	1	DECAL, Traction Control Symbols
0080	304427MA	1	DECAL, Face Headphones
0100	1751198YP	1	DECAL, Logo
0110	1751200YP	1	DECAL, Auger Housing
0230	1737871YP	1	DECAL, 1-6 Transmission Speed Control

Footnotes

The above parts group applies to the following Mfg. Nos.:

1695951 - Champion 9TP 24" Dual Stage Snowthrower

Gear Case Assembly

NOTE: Unless noted otherwise,
use the standard hardware torque
specification chart.

:alog_Data\MUR\Images\groups\assembly\1738600

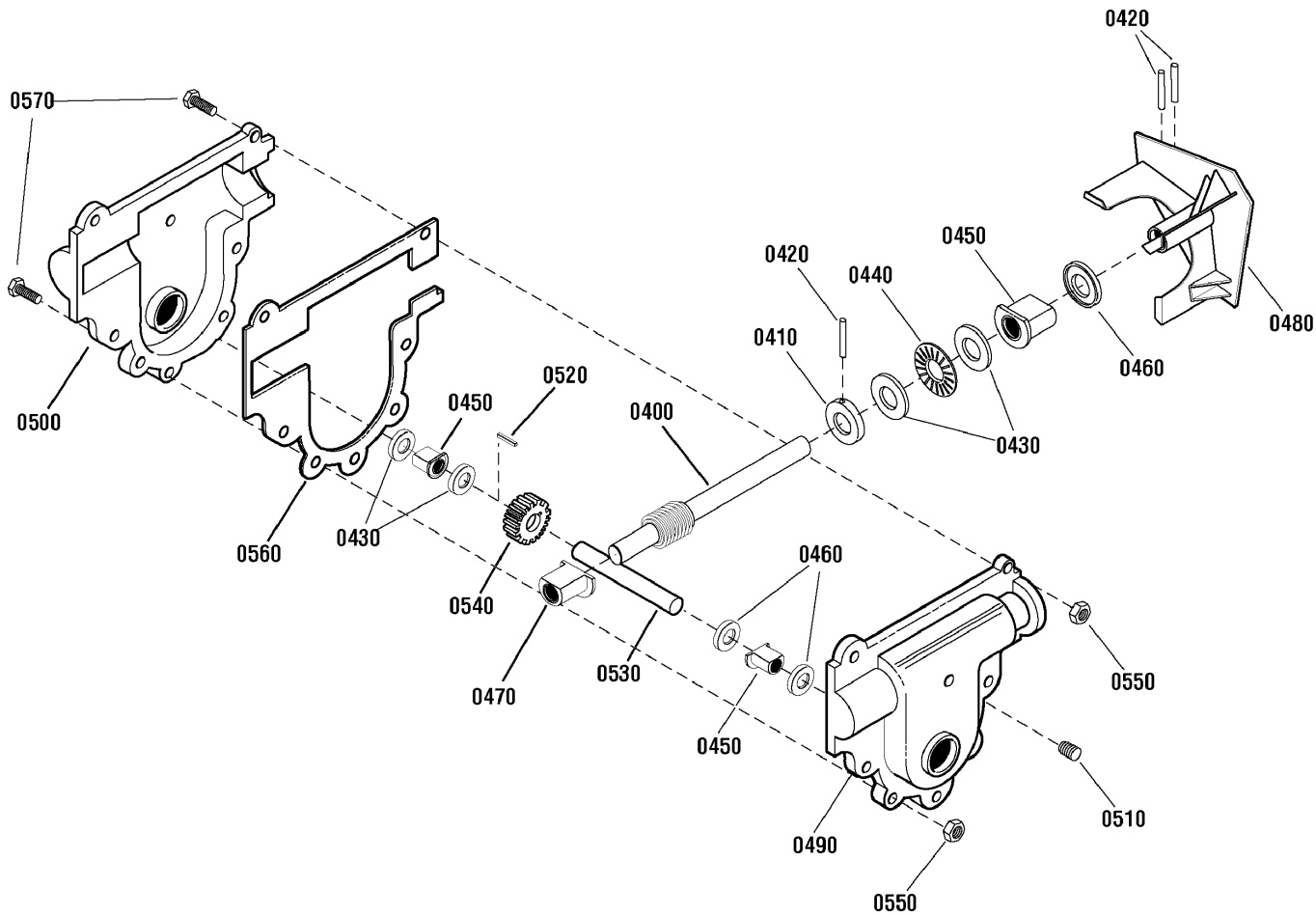

The above parts group applies to the following Mfg. Nos.:

1695951 - Champion 9TP 24" Dual Stage Snowthrower

Gear Case Assembly

REF NO	PART NO.	QTY.	DESCRIPTION
0400	1501191MA	1	SHAFT, Impeller
0410	580295MA	1	COLLAR, Thrust
0420	454565MA	3	PIN, Spring
0430	48275MA	4	WASHER, Thrust
0440	50684MA	1	BEARING, Roll, 3/4 ID x 1-1/4 OD
0450	50304MA	3	BEARING, Flange, 3/4 ID x 1 OD
0460	9566MA	3	SEAL, Oil
0470	50221MA	1	BEARING, Flange, 1/2 ID x 3/4 OD
0480	1740929AYP	1	IMPELLER
0490	10576MA	1	CASE, Gear, L.H.
0500	10577MA	1	CASE, Gear, R.H.
0510	9344MA	1	CAPSCREW, Hex Washer Head, Taptite, 3/8-16 x 1/2
0520	431787MA	1	KEY, Woodruf
0530	1501189MA	1	SHAFT, Auger
0540	51405MA	1	GEAR, Worm
0550	15X143MA	7	NUT, Flange Lock, 1/4-20
0560	51279MA	1	GASKET, Gear Case
0570	710025MA	7	CAPSCREW, 1/4-20 x 3/4, GR5

Footnotes

The above parts group applies to the following Mfg. Nos.:

1695951 - Champion 9TP 24" Dual Stage Snowthrower

Discharge Chute Group

NOTE: Unless noted otherwise,
use the standard hardware torque
specification chart.

atalog_Data\MUR\Images\groups\2980000\2989062

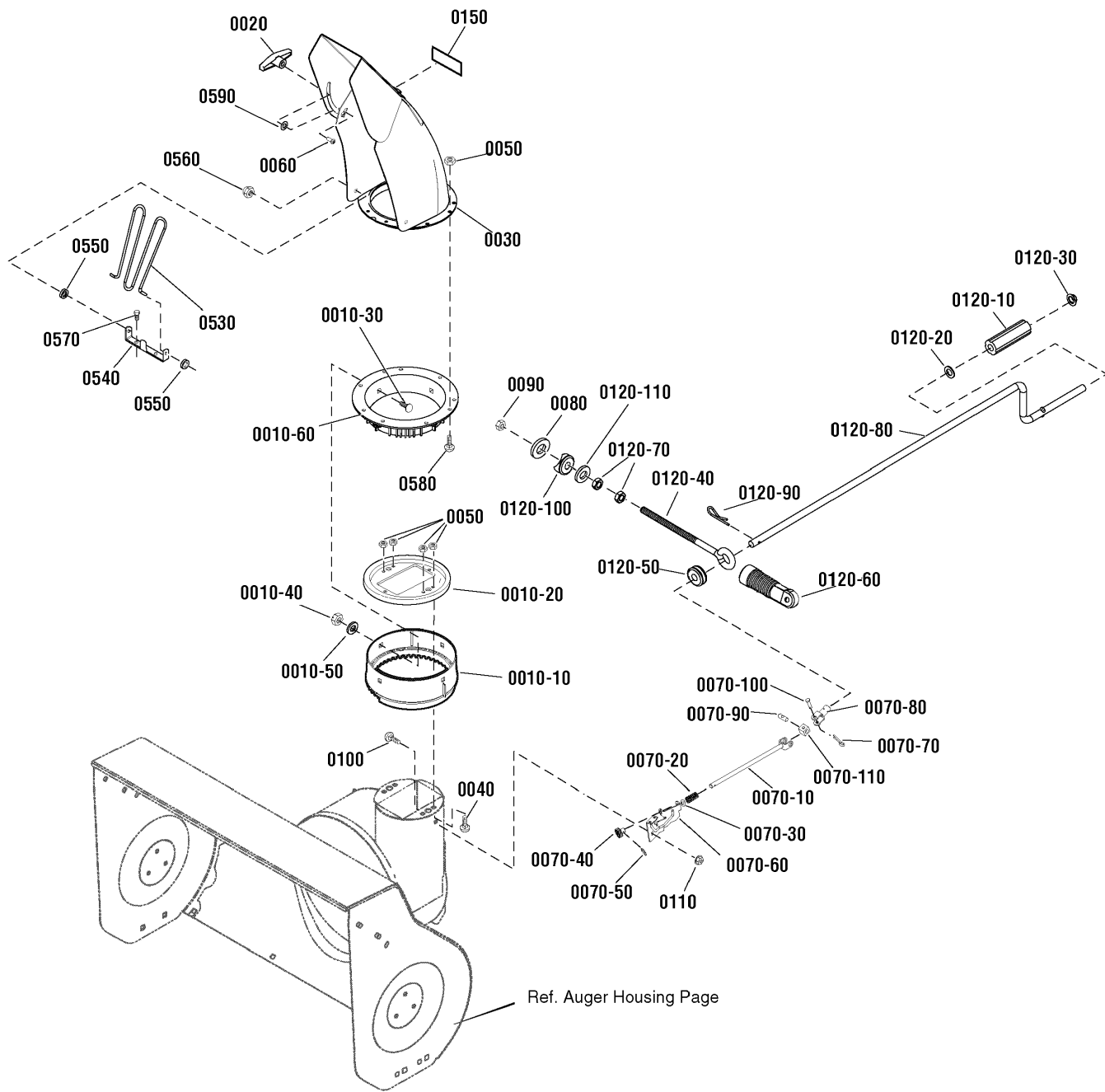

The above parts group applies to the following Mfg. Nos.:

1695951 - Champion 9TP 24" Dual Stage Snowthrower

Discharge Chute Group

REF NO	PART NO.	QTY.	DESCRIPTION
0010-10	1501282MA	1	RING, Outer Chute
0010-20	1501932YZMA	1	COLLAR, Chute
0010-30	2X100MA	4	BOLT, Carriage, 5/16-18 x 1
0010-40	71038MA	4	NUT, Hex Nylock, 5/16-18
0010-50	71071MA	4	WASHER, Flat, 3/8
0010-60	1741917YP	1	RING, Inner Chute
0020	1501260MA	1	KNOB, Wing, w/Nut, 5/16-18
0030	1736380AYP	1	CHUTE ASSEMBLY
0040	1935450SM	4	CAPSCREW, Hex Flange Head, 1/4-20 x 3/4, G5
0050	5025391SM	8	NUT, Nylock Flange, 1/4-20
0060	002X97MA	1	BOLT, Carriage, 5/16-18 x 1-1/2
--	1501534MA	1	GEAR & YOKE ROD ASSEMBLY (Includes Ref. Nos. 0070-10, 0070-20, 0070-30, 0070-40, 0070-50, 0070-60, 0070-70, 0070-80, 0070-90, 0070-100 & 0070-110)
0070-10	1501533YZMA	1	ROD, Yoke Crank
0070-20	164X37MA	1	SPRING, Compression
0070-30	017X48MA	1	WASHER, Flat, 3/8
0070-40	1501067MA	1	GEAR, 9 Tooth
0070-50	1501293MA	1	PIN, Hair
0070-60	1740591AYP	1	BRACKET, Chute Gear
0070-70	579493MA	1	PIN, Cotter
0070-80	1501075YZMA	1	YOKE TUBE ASSEMBLY
0070-90	578060MA	1	PIN, Universal Joint
0070-100	578309MA	1	PIN, Clevis
0070-110	578063MA	1	BLOCK, Universal Pivot
0080	71072MA	1	WASHER, Flat, 7/16
0090	71046MA	1	NUT, Nylock, 3/8-16
0100	02X101MA	1	BOLT, Carriage, 1/4-20 x 3/4
0110	15X145MA	1	NUT, Hex Nylock, 1/4-20
--	1740589MA	1	ROD ASSEMBLY (Includes Ref. Nos. 0120-10, 120-20, 0120-30, 0120-40, 0120-50, 0120-60, 0120-70, 0120-80, 0120-90, 0120-100 & 0120-110)
0120-10	307399MA	1	GRIP, Chute
0120-20	309312MA	1	WASHER, Flat, 7/16
0120-30	73664MA	1	PUSHNUT, 3/8
0120-40	1501456MA	1	EYEBOLT, 3/8-16 x 6-1/2
0120-50	148MA	1	GROMMET, Eyebolt
0120-60	1501457MA	1	BOOT, Eyebolt
0120-70	71045MA	2	NUT, Hex Jam, 3/8-16
0120-80	1501074YZMA	1	CRANK, Chute Turn
0120-90	0031X6MA	1	PIN, Hair 3/8 x 1-5/8
0120-100	309344MA	2	ADAPTOR, Boot to Handle
0120-110	71072MA	1	WASHER, Flat, 7/16

Footnotes

The above parts group applies to the following Mfg. Nos.:

1695951 - Champion 9TP 24' Dual Stage Snowthrower

Discharge Chute Group

NOTE: Unless noted otherwise, use the standard hardware torque specification chart.

atalog_Data\MUR\Images\groups\2980000\2989062

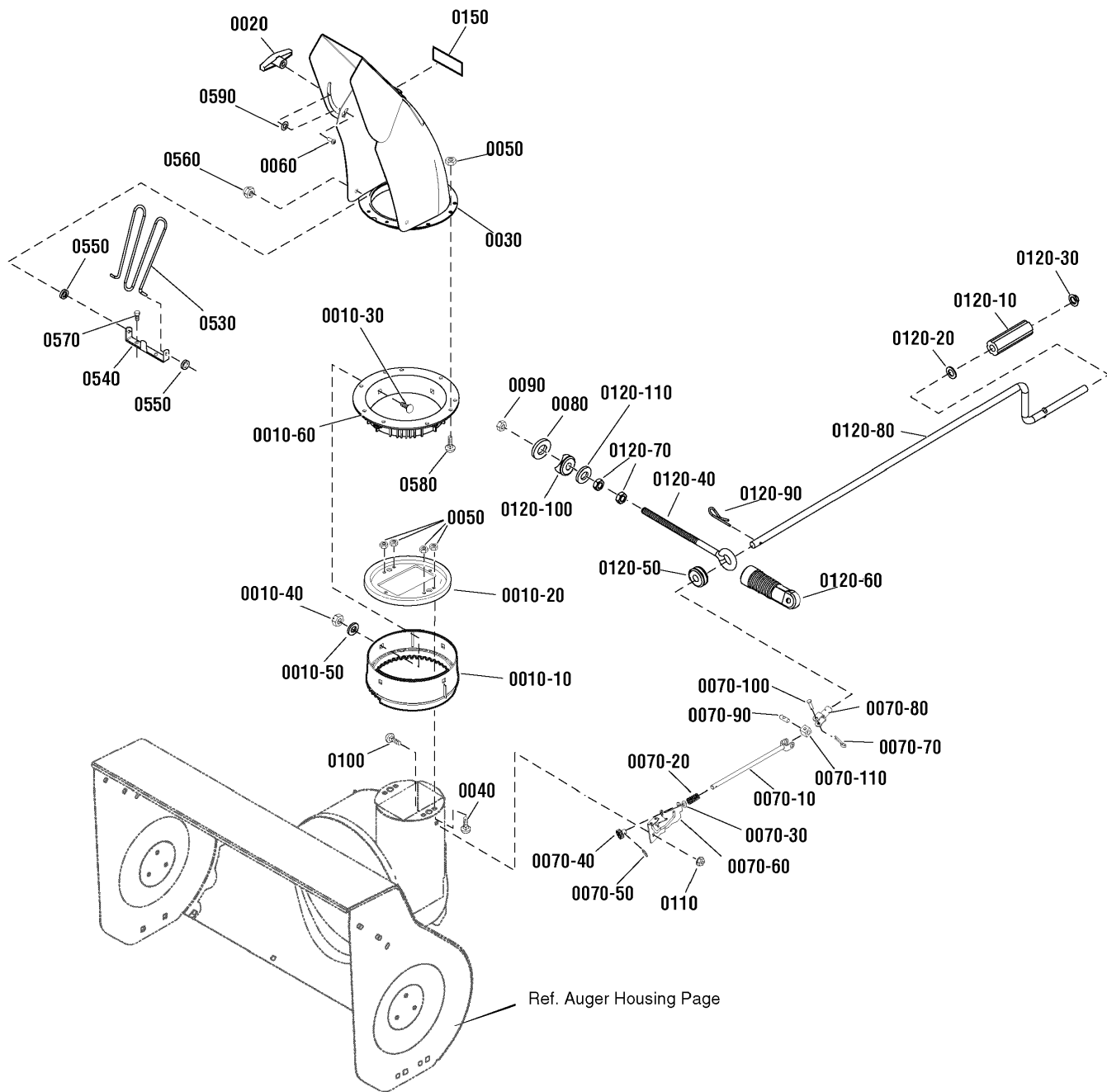

The above parts group applies to the following Mfg. Nos.:

1695951 - Champion 9TP 24" Dual Stage Snowthrower

Discharge Chute Group

REF NO	PART NO.	QTY.	DESCRIPTION
0150	1733601	2	DECAL, Hinge
0530	1733475SM	1	GUARD, Chute
0540	1737683YP	1	BRACKET, Chute Guard
0550	1738174YP	2	GROMMET, Chute Guard
0560	1960140SM	2	PUSHNUT, 3/16
0570	1925003SM	2	CAPSCREW, Hex Washer Head, Taptite, 1/4-20 x 1/2
0580	7091530SM	4	BOLT, Carriage, 1/4-20 x 3/4, G5
0590	2860210SM	2	WASHER, Nylon, 3/8

Footnotes

The above parts group applies to the following Mfg. Nos.:

1695951 - Champion 9TP 24" Dual Stage Snowthrower

Hardware Identification & Torque Specifications

Torque Specification Chart								
FOR STANDARD METRIC MACHINE HARDWARE (Tolerance ± 20%)								
Property Class	5.6		8.8		10.9		12.9	
	Class 5.6		Class 8.8		Class 10.9		Class 12.9	
Size Of Hardware	in/lbs		in/lbs		in/lbs		in/lbs	
	ft/lbs	Nm.	ft/lbs	Nm.	ft/lbs	Nm.	ft/lbs	Nm.
M3	5.88	.56	13.44	1.28	19.2	1.80	22.92	2.15
M4	13.44	1.28	30.72	2.90	43.44	4.10	52.56	4.95
M5	26.4	2.50	60.96	5.75	5.97	8.10	7.15	9.7
M6	44.64	4.3	7.3	9.9	10.3	14	12.1	16.5
M7	5.2	7.1	12.1	16.5	16.9	23	19.9	27
M8	7.7	10.5	17.7	24	25	34	29	40
M10	15	21	35	48	50	67	59	81
M12	26	36	61	83	86.2	117	103	140
M14	42	58	101	132	136	185	162	220
M16	64	88	147	200	210	285	250	340
M18	89	121	202	275	287	390	346	470
M20	126	171	290	390	405	550	486	660
M22	169	230	390	530	559	745	656	890
M24	217	295	497	375	708	960	840	1140
M27	320	435	733	995	1032	1400	1239	1680
M30	435	590	995	1350	1401	1900	1681	2280
M33	590	800	1349	1830	1902	2580	2278	3090
M36	759	1030	1740	2360	2441	3310	2935	3980
M39	988	1340	2249	3050	3163	4290	3798	5150

The guides and ruler furnished below are designed to help you select the appropriate hardware.

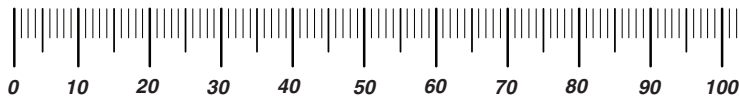

Nut, M8

Thread Diameter (mm)
Inside Diameter (in)
Threads per inch

Nut, 1/2-16

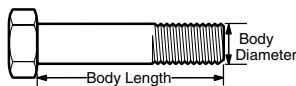

Screw, M8- 1.25 x 25

Thread Diameter (mm)
Body Diameter
Distance between threads (mm)
Threads per inch
Body Length (mm)
Body Length (in)

Screw, 1/2- 16 x 2

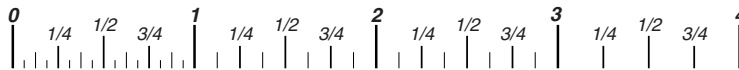

Standard Hardware Sizing

When a washer or nut is identified as **1/2"** (M8), this is the *Nominal size*, meaning the *inside diameter* is 1/2 inch (8mm metric thread diameter); if a second number is present it represents the *threads per inch* (distance between threads).

When bolt or capscrew is identified as **1/2 - 16 x 2"** (M8 - 1.25 x 50), this means the *Nominal size*, or body diameter is 1/2 inch (8mm metric thread diameter), the second number, 16, represents the *threads per inch*, (1.25 thread diameter). The final number is the body length of the bolt or screw, 2 inches (50mm).

Torque Specification Chart						
FOR STANDARD MACHINE HARDWARE (Tolerance ± 20%)						
Hardware Grade	No Marks		No Marks		No Marks	
	SAE Grade 2		SAE Grade 5		SAE Grade 8	
Size Of Hardware	in/lbs		in/lbs		in/lbs	
	ft/lbs	Nm.	ft/lbs	Nm.	ft/lbs	Nm.
8-32	19	2.1	30	3.4	41	4.6
8-36	20	2.3	31	3.5	43	4.9
10-24	27	3.1	43	4.9	60	6.8
10-32	31	3.5	49	5.5	68	7.7
1/4-20	66	7.6	8	10.9	12	16.3
1/4-28	76	8.6	10	13.6	14	19.0
5/16-18	11	15.0	17	23.1	25	34.0
5/16-24	12	16.3	19	25.8	29	34.0
3/8-16	20	27.2	30	40.8	45	61.2
3/8-24	23	31.3	35	47.6	50	68.0
7/16-14	30	40.8	50	68.0	70	95.2
7/16-20	35	47.6	55	74.8	80	108.8
1/2-13	50	68.0	75	102.0	110	149.6
1/2-20	55	74.8	90	122.4	120	163.2
9/16-12	65	88.4	110	149.6	150	204.0
9/16-18	75	102.0	120	163.2	170	231.2
5/8-11	90	122.4	150	204.0	220	299.2
5/8-18	100	136	180	244.8	240	326.4
3/4-10	160	217.6	260	353.6	386	525.0
3/4-16	180	244.8	300	408.0	420	571.2
7/8-9	140	190.4	400	544.0	600	816.0
7/8-14	155	210.8	440	598.4	660	897.6
1-8	220	299.2	580	788.8	900	1,244.0
1-12	240	326.4	640	870.4	1,000	1,360.0

NOTES

- These torque values are to be used for all hardware excluding: locknuts, self-tapping screws, thread forming screws, sheet metal screws and socket head setscrews.
- Recommended seating torque values for locknuts:
 - for prevailing torque locknuts - use 65% of grade 5 torques.
 - for flange whizlock nuts and screws - use 135% of grade 5 torques.
- Unless otherwise noted on assembly drawings, all torque values must meet this specification.

Common Hardware Types

Hex Head Capscrew



Washer



Lockwasher

Carriage Bolt



Hex Nut

Wrench & Fastener Size Guide

1/4" Bolt or Nut Wrench—7/16"	5/16" Bolt or Nut Wrench—1/2"	3/8" Bolt or Nut Wrench—9/16"	7/16" Bolt or Nut Wrench (Bolt)—5/8" Wrench (Nut)—11/16"	1/2" Bolt or Nut Wrench—3/4"
M6 Bolt or Nut Wrench—10mm	M8 Bolt or Nut Wrench—13mm	M10 Bolt or Nut Wrench—17mm	M12 Bolt or Nut Wrench—19mm	M14 Bolt or Nut Wrench—22mm

CHAMPION

**IT IS THE POLICY OF BRIGGS & STRATTON CORP. TO IMPROVE ITS PRODUCTS
WHENEVER IT IS POSSIBLE AND PRACTICAL TO DO SO. WE RESERVE THE RIGHT TO
MAKE CHANGES OR ADD IMPROVEMENTS AT ANY TIME WITHOUT INCURRING ANY
OBLIGATION TO MAKE SUCH CHANGES ON PRODUCTS.**

Briggs & Stratton Yard Power Products Group

3515 N. 124 Street / PO Box 702
Wauwatosa, WI 53222 USA

www.murray.com

© Copyright 2010 by Briggs & Stratton Corporation
Milwaukee, WI, USA. All rights reserved