

CHAMPION

Parts Manual

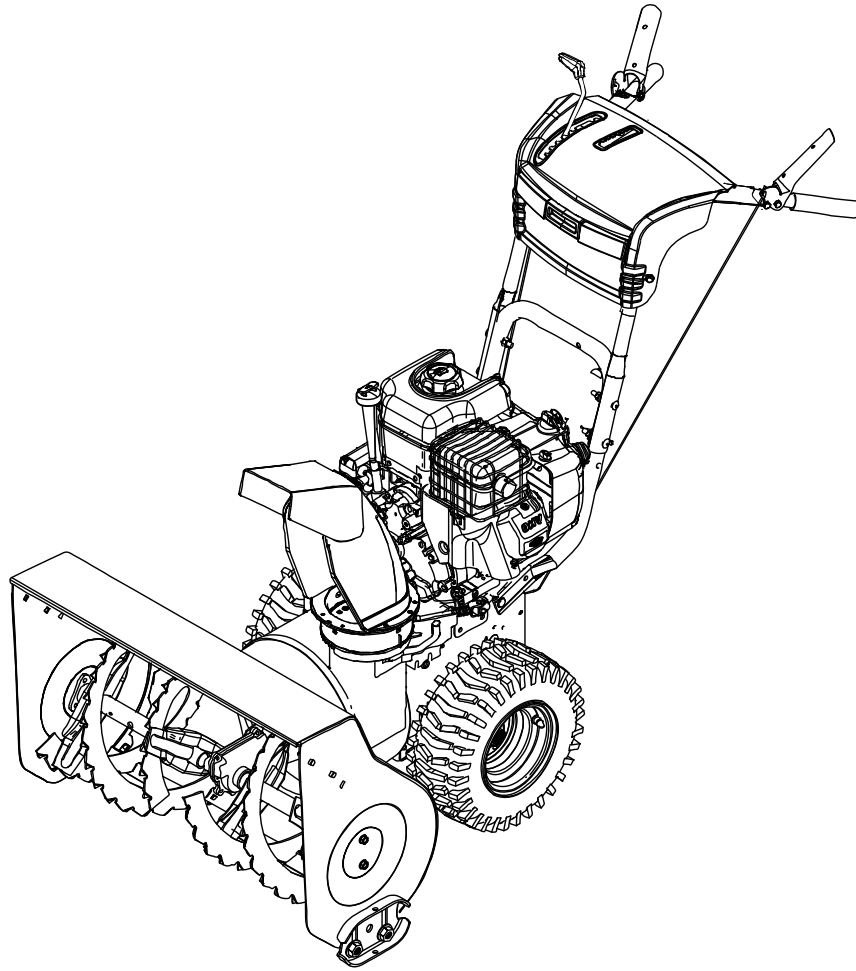

ST1074BS

29" Dual Stage Snowthrower

Models

Mfg. No.	Description
1696411-00	ST1074BS, Champion 14.5TP 29" Dual Stage Snowthrower (2013)

Manual Part No. 1757472

Revision A

Rev. Date: 7/15/2013

PRODUCT COMPONENTS	PAGES
Handles & Controls Group	4
Engine & Frame Group	8
Auger Drive Group	10
Auger Housing Group	12
Traction Drive Group	14
Transmission SERVICE PARTS - General Transmission H2	16
Wheels & Tires Group	18
Decals Group	20
Gear Case Assembly	22
Discharge Chute Group	24
Torque Specification Chart	Inside Back Cover

Handles & Controls Group

NOTE: Unless noted otherwise,
use the standard hardware torque
specification chart.

2991245

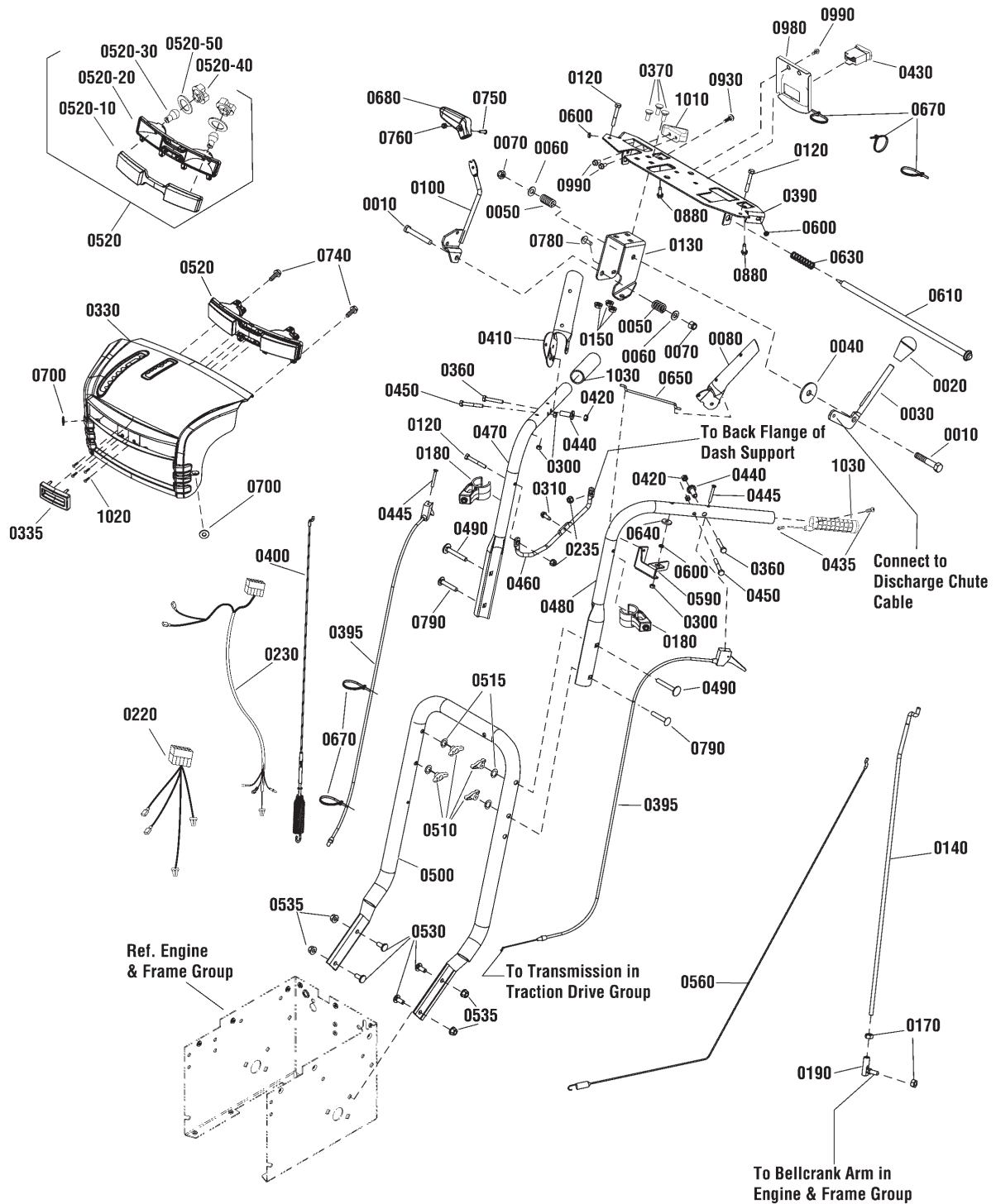

The above parts group applies to the following Mfg. Nos.:
1696411-00 - ST1074BS

Handles & Controls Group

REF NO	PART NO.	QTY.	DESCRIPTION
0010	703589	2	CAPSCREW, Hex Head, 3/8-16 x 2, G5
0020	1732470SM	1	KNOB, Deflector
0030	1736192YP	1	LEVER, Deflector
0040	703591	1	WASHER, 3/8 x 1-1/2 OD
0050	50786MA	2	SPRING, 3/4"
0060	703590	2	WASHER, Flat, 3/8 x 13/16 OD
0070	703117	2	NUT, Nylock, GR5, 3/8-16
0080	1739782AYP	1	LEVER, Clutch, L.H.
0100	703047	1	SPEED LEVER ASSEMBLY
0120	703588	3	CAPSCREW, Hex Head, 1/4-20 x 1 3/4, GR5
0130	1737684YP	1	BRACKET, Controls
0140	1737331YP	1	ROD, Speed Select
0150	703409	3	NUT, Hex, 5/16-18
0170	703331	2	NUT, Hex Flange Serrated Lock, 5/16-18
0180	1739510YP	2	BRACKET, Lower Mounting
0190	703224	1	BALL JOINT, Quick Release
0220	1752164YP	1	HARNESS, On/Off, HHG
0230	1755059YP	1	WIRING HARNESS
0235	703463	2	NUT, Hex Flange, ESNA, 1/4-20
0300	703232	4	NUT, Hex Lock ESNA Light 1/4-20
0310	703466	1	SCREW, Hex Washer Head, Taptite, 1/4-20 x 3/4
0330	1755373YP	1	PANEL ASSEMBLY
0335	1754422YP	1	FILLER STRIP, Center Piece
0360	1753529YP	3	BOLT, Shoulder, Hex Washer Head, 1/4 x 1-1/2
0370	703225	3	BOLT, Carriage, 5/16-18 x 3/4, G5
0390	1739500BMYP	1	SUPPORT, Dash
0395	1737510YP	2	CABLE, Steering Control
0400	703221	1	CABLE & SPRING ASSEMBLY, Auger Drive, R.H.
0410	1739783AYP	1	LEVER, Clutch, RH
0420	703412	2	NUT, Nylock, 10 x 24
0430	1752242YP	1	SWITCH, Heated Hand Grip
0435	703044	4	SCREW, Square, 1/8-20 x 1/32
0440	703223	2	SPACER, Stepped
0445	703134	2	BOLT, 10-24 x 1.5, GR5
0450	703045	2	CAPSCREW, Hex Head, 1/4-20 x 1-3/4, G5
0460	1737552YP	1	BRACE
0470	1737531AYP	1	HANDLE, Upper, R.H.
0480	1737532AYP	1	HANDLE, Upper, L.H.
0490	703168	2	CARRIAGE BOLT, 5/16-18 x 2.25
0500	1737274AYP	1	HANDLE, Lower
0510	703065	2	KNOB, Wing, 5/16-18

Footnotes

Note* See your local hardware store for replacement bulbs.

The above parts group applies to the following Mfg. Nos.:

1696411-00 - ST1074BS

Handles & Controls Group

NOTE: Unless noted otherwise,
use the standard hardware torque
specification chart.

2991245

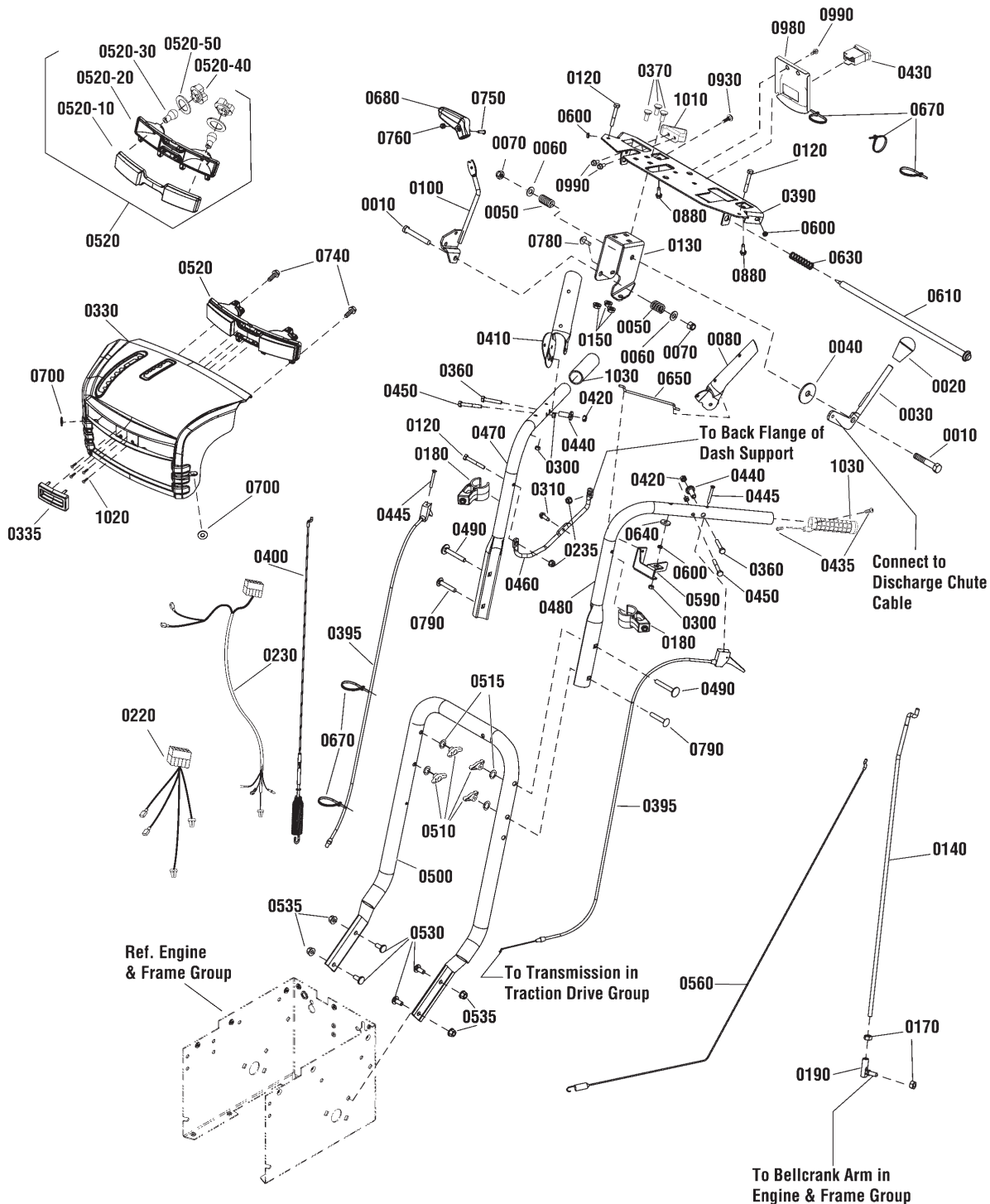

The above parts group applies to the following Mfg. Nos.:
1696411-00 - ST1074BS

Handles & Controls Group

REF NO	PART NO.	QTY.	DESCRIPTION
0515	703587	2	WASHER, Internal Tooth Lock, 5/16"
0520	1756613YP	1	LIGHT ASSEMBLY, LED (Incl. Ref. No. 0520-10, 0520-20, 0520-30, 0520-40 & 0520-50)
0520-10	1754421YP	1	LENS, Light, P19 (Included with Ref. No. 0520)
0520-20	1754420YP	1	LIGHT, Bezel, P19 (Included with Ref. No. 0520)
0520-30	-----	2	* BULB, Light, 12VAC, LED (Included with Ref. No. 0520)
0520-40	1736180YP	2	SOCKET & GASKET ASSEMBLY, Headlight (Included with Ref. No. 0520)
0520-50	1736179YP	2	GASKET, Single, Twin Light (Included with Ref. No. 0520)
0530	1737687YP	4	BOLT, Carriage, 5/16-18 x 3/4
0535	703222	4	NUT, Hex, KEPS, 5/16-18
0560	1737511YP	1	CABLE, Traction Drive
0590	1733505BMYP	1	BRKT, Pivot, Free Hand
0600	703124	1	SPACER, Powdered Metal
0610	1736363YP	1	ROD & SPRING ASSEMBLY
0630	2108360SM	1	SPRING, Compression
0640	703229	1	WASHER, 0.261ID x 0.84OD x 0.12
0650	1736360YP	1	ROD, Hold Down, 5-1/2"
0670	703586	5	TIE, Self Locking
0680	1733192SM	1	KNOB, Slot Speed
0700	703332	2	WASHER, 1/4
0740	703944	2	SCREW, Hex Washer Head, #10-16 x 0.375
0750	1960589SM	1	SCREW, Round Head Phillips, #10-24 x 3/4
0760	703412	1	NUT, Nylock, 10 x 24
0780	703466	1	SCREW, Hex Washer Head, Taptite, 1/4-20 x 3/4
0790	703059	2	BOLT, Conical, 5/16-18 x 2
0880	7091081SM	2	SCREW, Hex Washer, Self Tap, 1/4-15 x 3/4
0930	703101	1	BOLT, Carriage, 1/4-20 x 3/4
0980	1739861BMYP	1	BRACKET, Switch
0990	1960556SM	3	SCREW, Pan Head, Torx, 1/4-20 x 3/4, Taptite
1010	1739483AYP	1	POD, Chute Rotation, RH
1020	1753218YP	4	SCREW, Torx, 8/18 x 1/2
1030	1738124YP	2	HAND GRIP, Heated 1" Dia. x 5-1/4 Lg

Footnotes

Note* See your local hardware store for replacement bulbs.

The above parts group applies to the following Mfg. Nos.:

1696411-00 - ST1074BS

Engine & Frame Group

REF NO	PART NO.	QTY.	DESCRIPTION
0010	20M314-0141-H1	1	* ENGINE, 14.5 Gross TP Briggs & Stratton (Engine Model: 20M314-0141-H1)
0010-10	698109	1	CAP, Fuel
0010-20	796384	1	GUARD, Muffler
0010-30	699234	4	SCREW, Muffler Guard
0050	75246GS	4	CAPSCREW, Hex Head, Trilobular, 3/8-16 x 1-1/4
0080	1737509YP	1	PULLEY ASSEMBLY
0100	1916965SM	1	LOCKWASHER, Spring, 3/8
0110	2860768YP	1	CAPSCREW, Hex Head, 3/8-24 x 1-3/4, G8
0115	2157427SM	1	KEY, Parallel
0120	1737220YP	1	V-BELT, Multi Speed
0125	1733968YP	1	PULLEY ASSEMBLY
0130	585416MA	1	BELT, Auger, V4L 38.10 MF 05-10B
0140	1737377YP	1	STOP, Belt
0170	1960684SM	1	NUT, Hex KEPS, Conical Washer, 5/16-18
0171	1931335SM	1	BOLT, Carriage, 5/16-18 x 1 G5
0176	1960151SM	1	WASHER, 1/4 x 1-1/4 x 1/16
0177	1733095SM	1	SPACER, Powdered Metal
0178	1737329YP	1	BELLCRANK
0179	1737328AYP	1	BRACKET, Lower
0180	1737297YP	1	BRACKET, Support, Auger Idler
0190	1737347AYP	1	BRACKET, Guide Wheel
0191	1922837SM	1	CAPSCREW, Hex Head, 1/4-20 x 1-1/2 G5
0192	579860MA	1	SPOOL CABLE, Auger Control
0193	192432GS	2	NUT, Lock, Serrated, 1/4-20
0200	1502120MA	1	IDLER, Plastic, Ball Bearing
0210	1960251SM	1	NUT, Hex Jam, 3/8-16
0220	585781MA	1	BOLT, Carriage, 3/8-16 x 1-1/4
0230	1737296YP	1	IDLER, Auger
0250	1960027SM	2	WASHER, 1/2" Flat
0260	1733451SM	1	BRACKET & HUB ASSEMBLY, Spring
0270	0031X6MA	2	PIN, Hair
0280	1736381YP	1	PIN, Clevis
0290	1737221AYP	1	PANEL, Bottom
0300	1927429SM	7	SCREW, Hex Washer Head Taptite, 1/4-20 x 5/8
0310	1737350YP	1	SPRING, Torsional
0320	1737106ZYP	1	FRAME BOX
0330	1754138ZYP	1	PLATE, Engine Mount
0350	1664847SM	19	SCREW, Hex Washer Head Taptite, 5/16-18 x 3/4
0360	1750551YP	1	COVER, Belt
0370	1751355YP	2	SCREW, Hex Washer Head, SEMS, Taptite, 1/4-20 x 3/4
0420	7023590SM	1	COTTER PIN, 1/4" Self Locking

Footnotes

Note* To verify your specific engine model, please reference the ID Tag located on your engine. See your local Briggs & Stratton distributor for parts and service.

The above parts group applies to the following Mfg. Nos.:

1696411-00 - ST1074BS

Auger Drive Group

NOTE: Unless noted otherwise,
use the standard hardware torque
specification chart.

2989780

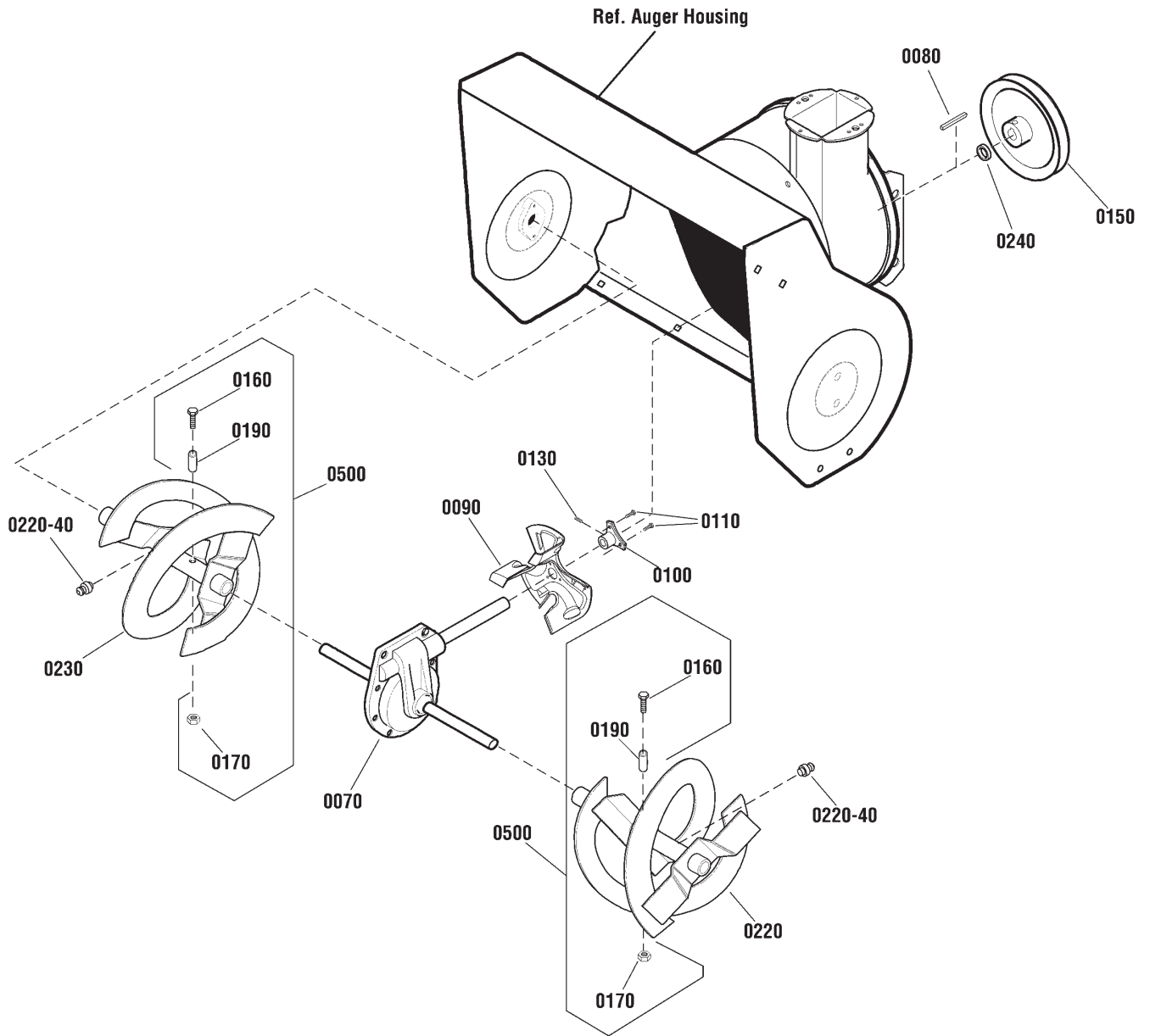

The above parts group applies to the following Mfg. Nos.:
1696411-00 - ST1074BS

Auger Drive Group

REF NO	PART NO.	QTY.	DESCRIPTION
0070	1752898YP	1	GEAR CASE ASSEMBLY, 29"
0080	056534MA	1	KEY, Square, 3/16 x 3/4
0090	1739094BMYP	1	IMPELLER
0100	1739073YP	1	HUB, Impeller
0110	1924856SM	3	SCREW, Hex Washer Head, Taptite, 5/16-18 x 1/2
0130	7090848SM	3	SET SCREW, Socket Head, 5/16-18 x 1/2
0150	1501211MA	1	PULLEY, 8.4 V4L .67 ID, Hybrid
0160	703057	2	CAPSCREW, Hex Head, 1/4-20 x 1-3/4
0170	703251	2	NUT, Hex Center Lock, 1/4-20
0190	703058	2	SPACER, Sleeve, 1/4 x 1/2"
0220	1738031BCYP	1	AUGER, L.H., 29" (Includes Ref. No. 0220-40)
0230	1738032BCYP	1	AUGER, R.H., 29" (Includes Ref. No. 0220-40)
0220-40	10104MA	2	FITTING, Grease
0240	1501158MA	1	SPACER, Friction Pulley
0500	1501216MA	1	KIT, Shear Bolt (Includes Ref. Nos. 0160, 0170 & 0190)

Footnotes

The above parts group applies to the following Mfg. Nos.:

1696411-00 - ST1074BS

Auger Housing Group

2991197

NOTE: Unless noted otherwise,
use the standard hardware torque
specification chart.

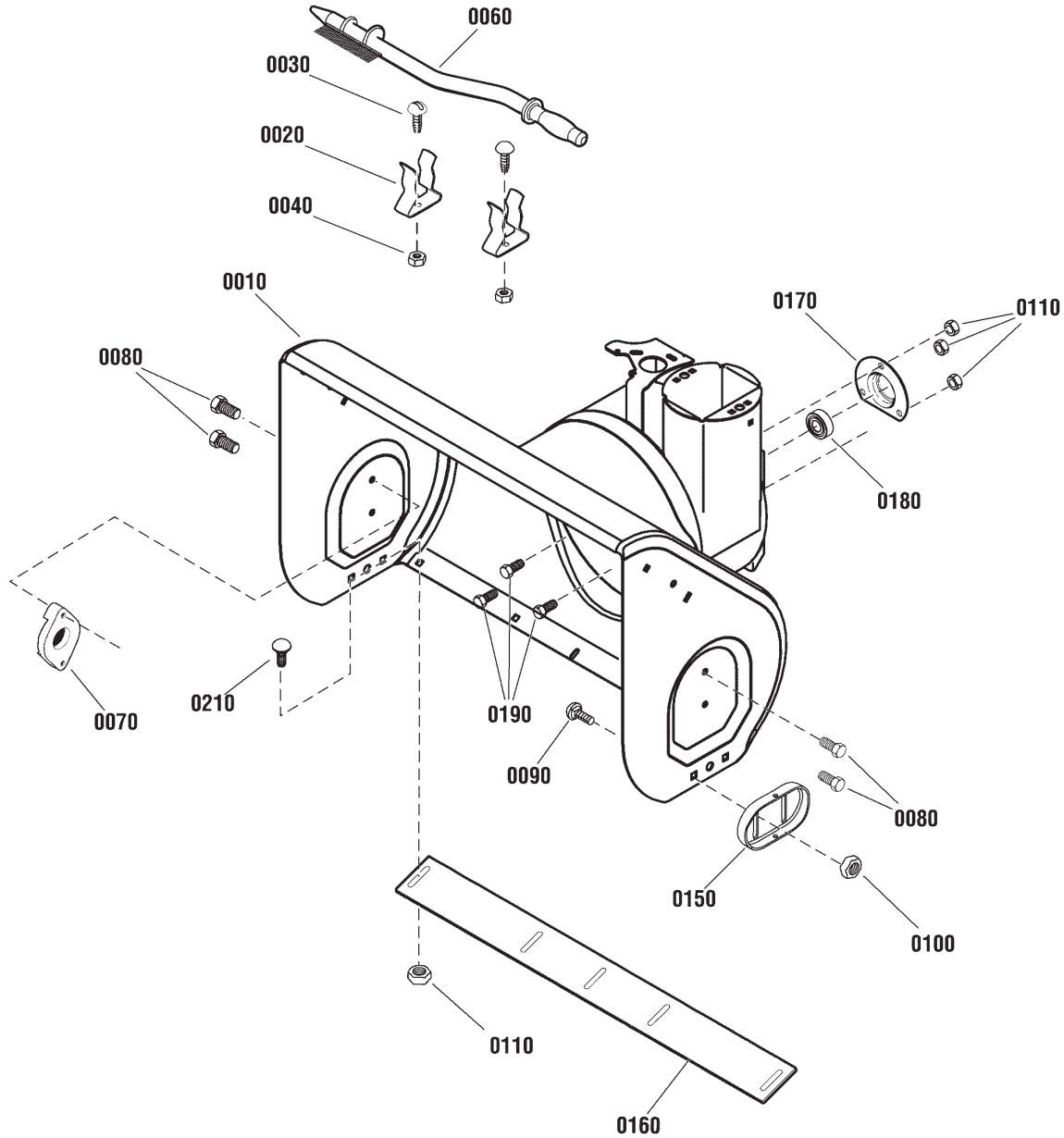

The above parts group applies to the following Mfg. Nos.:

1696411-00 - ST1074BS

Auger Housing Group

REF NO	PART NO.	QTY.	DESCRIPTION
0010	1687752YP	1	HOUSING, Auger, 29
0020	1736620YP	2	CLIP, Retainer
0030	1960569SM	2	SCREW, Truss Head, Torx #10-24 x 3/8
0040	7091290SM	2	NUT, Nylock, 10 x 24
0060	1736094YP	1	BRUSH, Cleanout
0070	53757MA	2	BEARING, Auger Shaft
0080	25X021MA	4	SCREW, Hex Head, 5/16-18 x 3/4
0090	7091547YP	4	BOLT, Carriage, 3/8-16 x 3/4, G5
0100	7091619SM	4	NUT, Hex Flange, 3/8-16
0110	1931277SM	7	NUT, Hex Flange, Serrated, 5/16-18
0150	1750222YP	2	SKID SHOE, Reversible
0160	1738334AYP	1	BLADE, Scraper, 29
0170	1756809YP	1	RETAINER, Ball Bearing
0180	1705897SM	1	BEARING, Ball
0190	001X45MA	3	BOLT, Hex, 5/16-18 x 5/8
0210	7090799SM	4	BOLT, Carriage, 5/16-1/8 x 5/8, G5

Footnotes

The above parts group applies to the following Mfg. Nos.:

1696411-00 - ST1074BS

Traction Drive Group

NOTE: Unless noted otherwise,
use the standard hardware torque
specification chart.

2987638

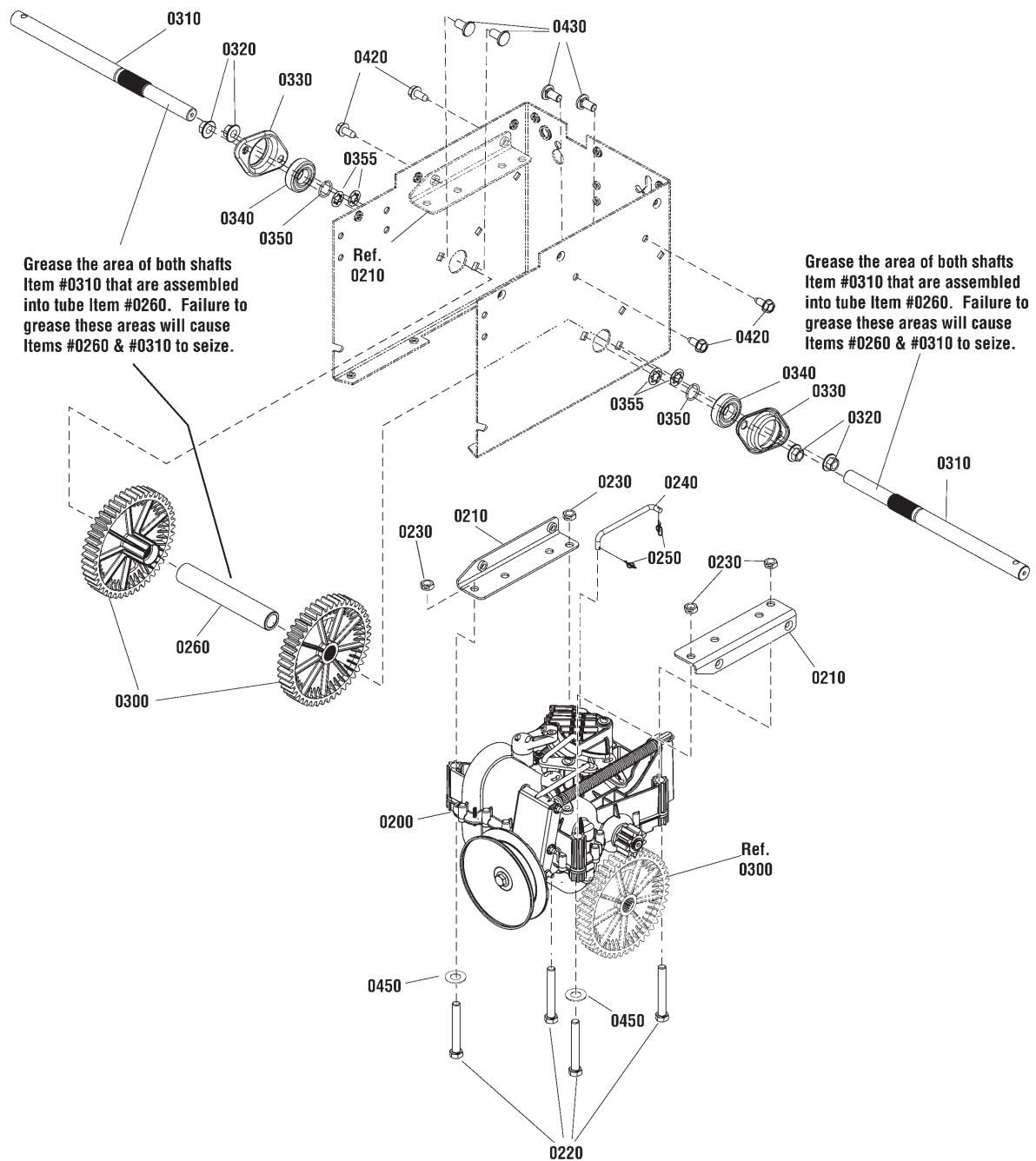

The above parts group applies to the following Mfg. Nos.:

1696411-00 - ST1074BS

Traction Drive Group

REF NO	PART NO.	QTY.	DESCRIPTION
0200	1733972YP	1	* TRANSMISSION, General Transmission H2
0210	1737267AYP	2	BRACKET
0220	7091557SM	4	CAPSCREW, Hex Head, 3/8C x 2-3/4 GR5
0230	1960251SM	4	NUT, Hex Jam, 3/8-16
0240	1737330YP	1	ROD, Speed Select
0250	7023590SM	2	COTTER PIN, 1/4" Self Locking
0260	1737310YP	1	TUBE, Support
0300	1737311YP	2	GEAR, Drive
0310	1737309YP	2	AXLE
0320	1928352SM	4	NUT, Hex Flange, Whiz Lock Large, 3/8-16
0330	1736396YP	2	RETAINER, Bearing
0340	53263MA	2	BEARING, Ball
0350	1737742YP	2	RING, Retaining
0355	7013847YP	4	RETAINER, Bolt 3/8"
0420	1664847SM	4	SCREW, Hex Washer Head Taptite, 5/16-18 X 3/4
0430	1737686YP	4	BOLT, Carriage, FH GR 5, 3/8-16 x 3/4
0450	703184	2	WASHER, Flat, 3/8

Footnotes

Note* See Transmission Assembly Group for detailed service parts.

The above parts group applies to the following Mfg. Nos.:

1696411-00 - ST1074BS

Transmission SERVICE PARTS - General Transmission H2

NOTE: Unless noted otherwise,
use the standard hardware torque
specification chart.

1733972

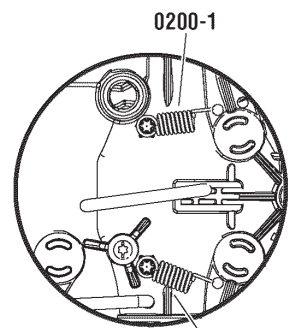
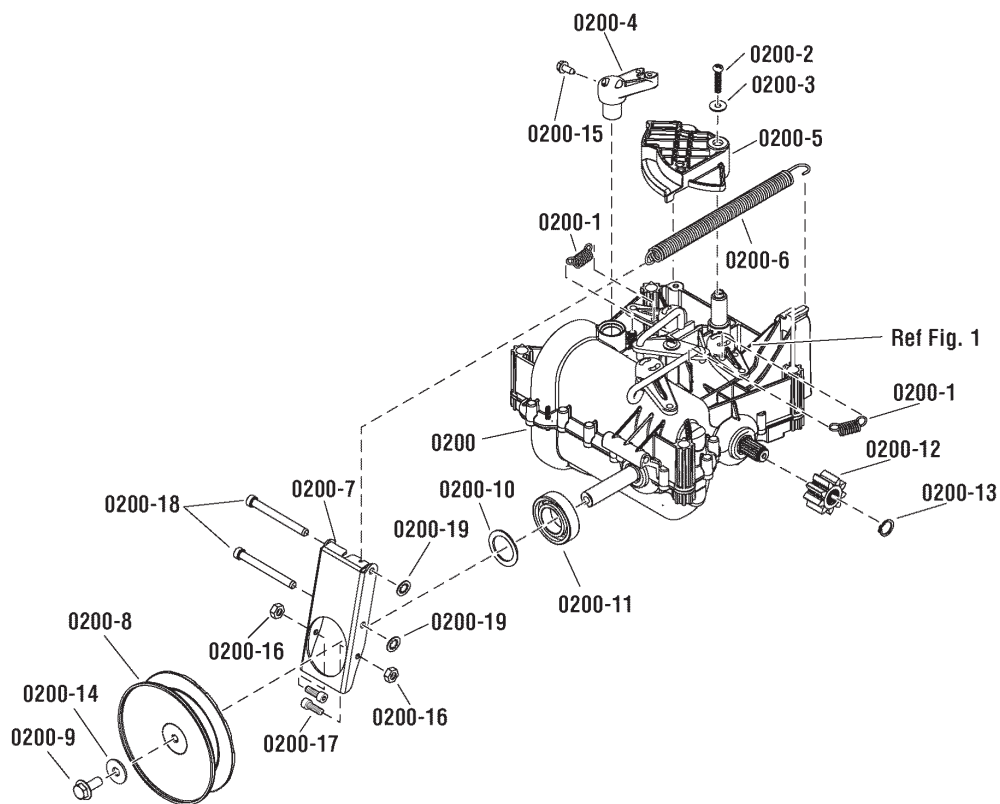

Fig. 1
Top View of Transmission

The above parts group applies to the following Mfg. Nos.:
1696411-00 - ST1074BS

Transmission SERVICE PARTS - General Transmission H2

REF NO	PART NO.	QTY.	DESCRIPTION
0200	1733972YP	1	TRANSMISSION, Complete General Transmission H2
0200-1	1739646YP	2	SPRING, Traction, 8.75 Inches
0200-2	1739645YP	1	SCREW, 5 X 25
0200-3	1739641YP	1	WASHER, 5.3 X 15 X 1.2.ipt
0200-4	1739642YP	1	LEVER
0200-5	1739644YP	1	CAM, Control
0200-6	1739640YP	1	SPRING, Variator
0200-7	1739625YP	1	SHIFT ARM
0200-8	1739624YP	1	PULLEY ASSEMBLY
0200-9	1739622YP	1	SCREW, M8x20 left
0200-10	1739636YP	1	WASHER, 25 X 35 X 1.5
0200-11	1739639YP	1	BEARING, 6005 2RS
0200-12	1739648YP	2	GEAR
0200-13	1739647YP	2	RETAINER
0200-14	1739623YP	1	WASHER, 0.8 X 27 X 3
0200-15	1739643YP	4	SCREW, 4 X 16
0200-16	1739626YP	2	NUT
0200-17	1739629YP	2	BOLT, Allen-Head, CHC M5 X 1.2
0200-18	1739632YP	2	PIN
0200-19	1739634YP	4	WASHER, Starlock

Footnotes

The above parts group applies to the following Mfg. Nos.:

1696411-00 - ST1074BS

Wheels & Tires Group

NOTE: Unless noted otherwise,
use the standard hardware torque
specification chart.

2990485

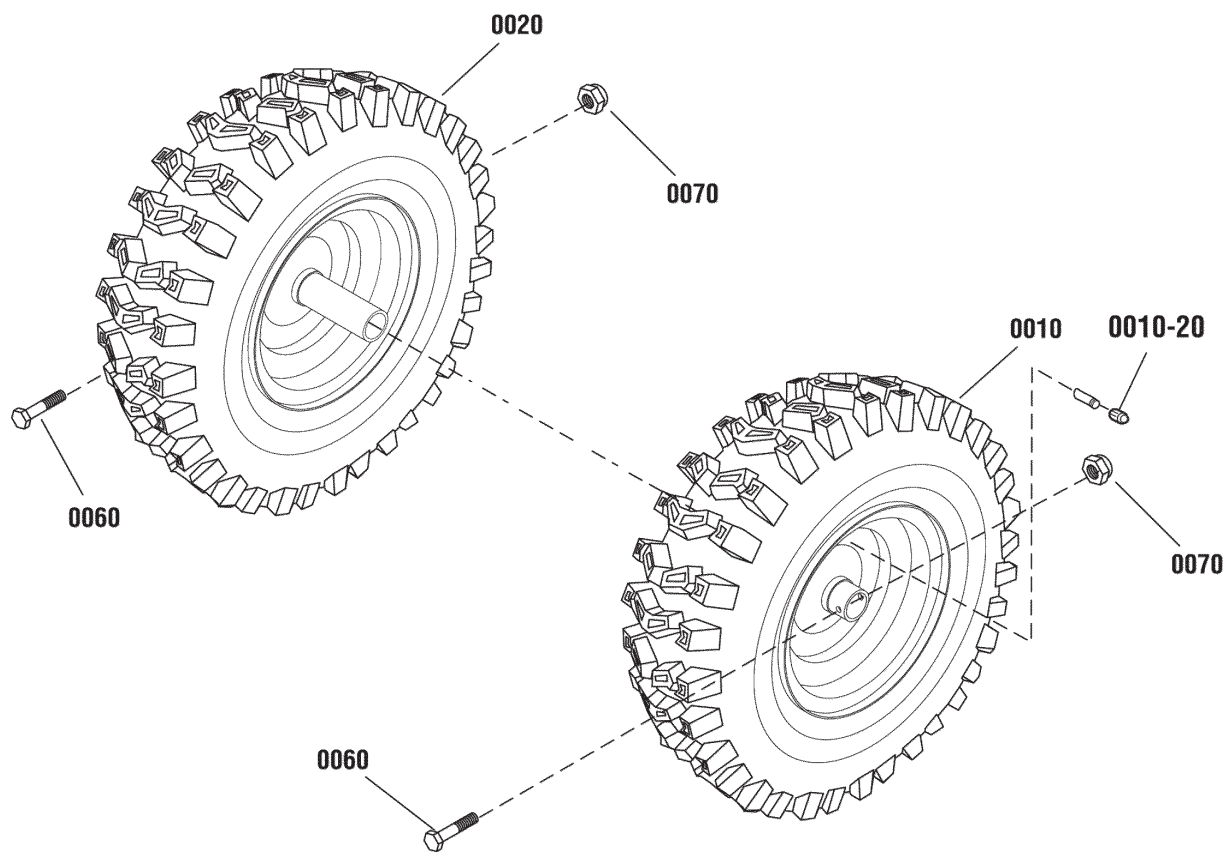

The above parts group applies to the following Mfg. Nos.:

1696411-00 - ST1074BS

Wheels & Tires Group

REF NO	PART NO.	QTY.	DESCRIPTION
0010	1735357YP	1	WHEEL & TIRE ASSEMBLY, 4.80-8, L.H. (Includes Ref. 0010-20)
0020	1735358YP	1	WHEEL & TIRE ASSEMBLY, 4.80-8, R.H. (Includes Ref. 0010-20)
0010-20	2172353SM	1	VALVE STEM & CAP
0060	577015MA	2	BOLT, Hex, 1/4-20 x 1-3/4, G5
0070	15X145MA	2	NUT, Hex, Nylock, 1/4-20

Footnotes

The above parts group applies to the following Mfg. Nos.:

1696411-00 - ST1074BS

Decals Group

NOTE: Unless noted otherwise, use the standard hardware torque specification chart.

2991247

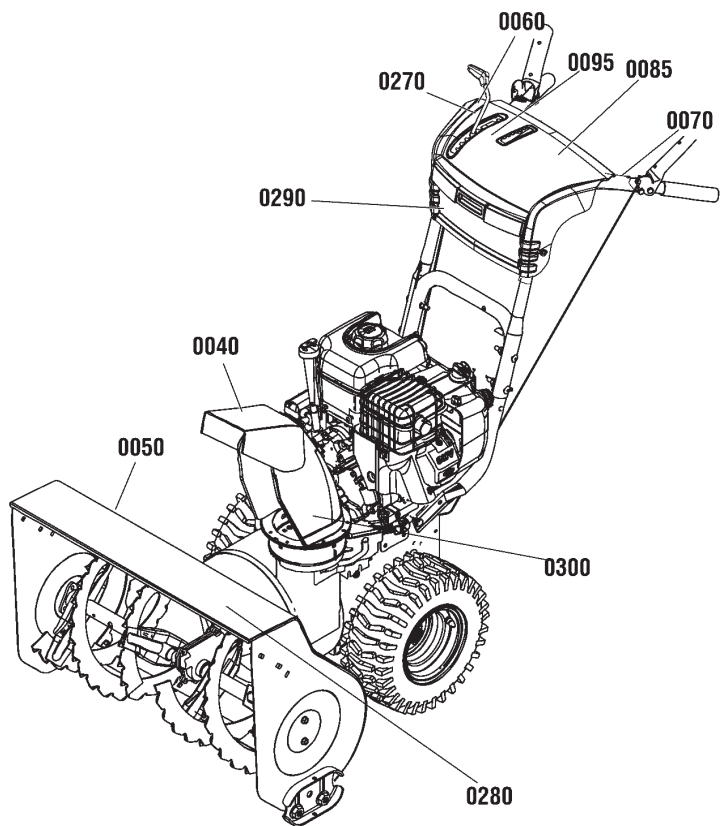

0040



0050



0060



0070

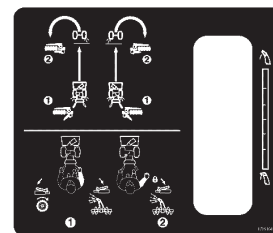

0085



0095



0270



0240



0250



0300



0290



0280

The above parts group applies to the following Mfg. Nos.:
1696411-00 - ST1074BS

Decals Group

REF NO	PART NO.	QTY.	DESCRIPTION
0040	1727207SM	1	DECAL, Chute Warning, Export
0050	1737867YP	1	DECAL, Danger Auger Icons
0060	1753133YP	1	DECAL, Auger Control Symbols
0070	1753134YP	1	DECAL, Traction Control Symbols
0085	1755304YP	1	DECAL, Controls
0095	1736616YP	1	DECAL, Shift
0240	1754246YP	1	DECAL, Powered by Briggs
0250	1754247YP	1	DECAL, Assembled in USA
0270	1755584YP	1	DECAL, Do Not Shift
0280	1756746YP	1	DECAL, Logo, Housing
0290	1757281YP	1	DECAL, Logo, Dash
0300	1757284YP	2	DECAL, Logo, Chute

Footnotes

The above parts group applies to the following Mfg. Nos.:

1696411-00 - ST1074BS

Gear Case Assembly

NOTE: Unless noted otherwise,
use the standard hardware torque
specification chart.

1752897

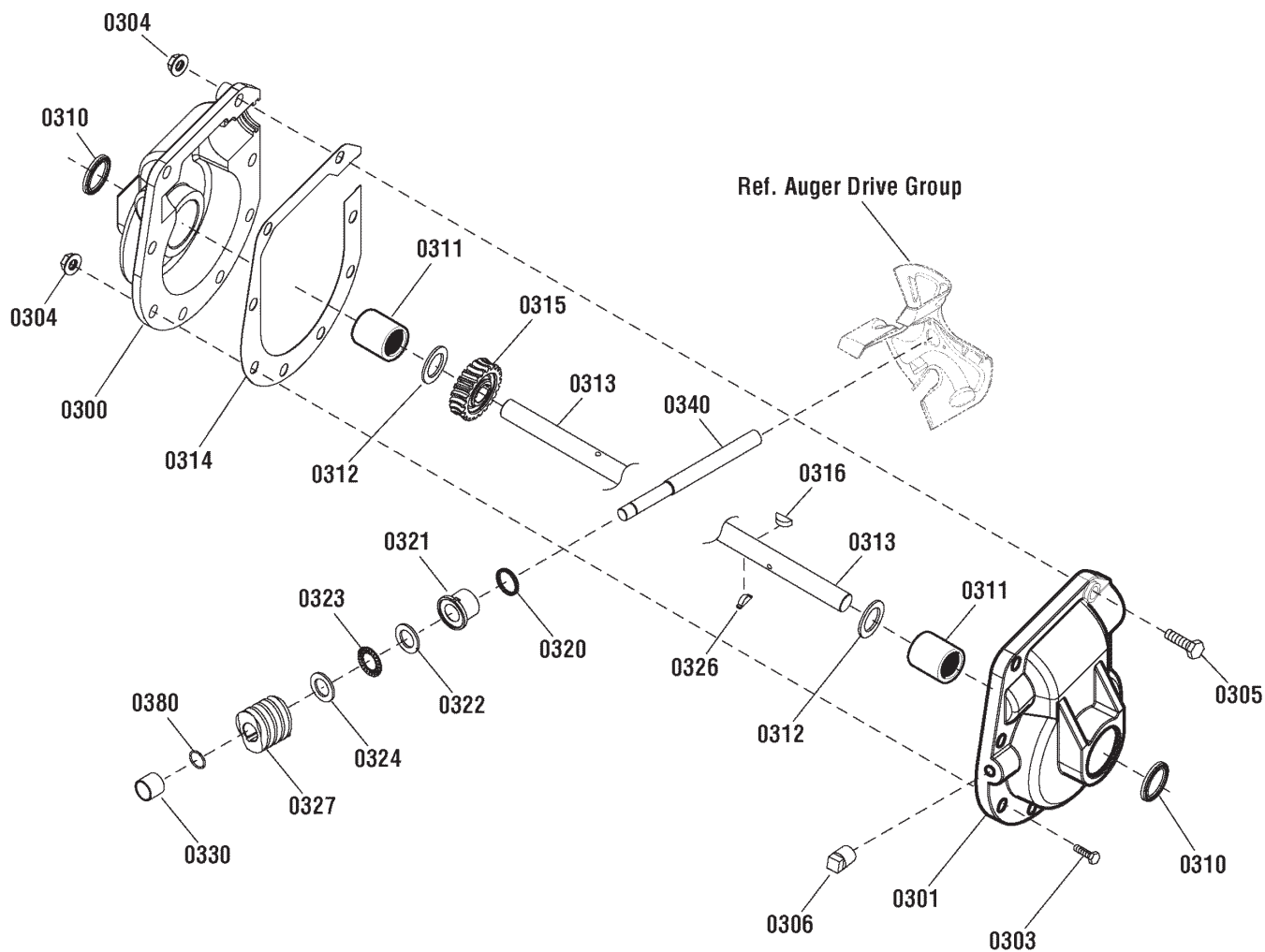

The above parts group applies to the following Mfg. Nos.:
1696411-00 - ST1074BS

Gear Case Assembly

REF NO	PART NO.	QTY.	DESCRIPTION
0300	896MA	1	CASE, Gear, RH
0301	895MA	1	CASE, Gear, LH
0303	910828MA	7	BOLT, Hex, 5/16-24 x 1
0304	71100MA	8	NUT, Hex Flange, Serrated Lock, 5/16-24
0305	330434MA	1	CAPSCREW, Hex Head, 5/16-24
0306	53749MA	1	PLUG, Pipe
0310	780151MA	2	SEAL, Oil
0311	53743MA	2	BEARING, Sleeve, 1 x 1-1/4 x 1
0312	53748MA	2	WASHER, Flat, 1-1-1/2
0313	760528MA	1	SHAFT, Auger Out, 29"
0314	897MA	1	GASKET
0315	1752500YP	1	GEAR, Worm, 22T
0316	73905MA	1	KEY, Woodruff
0320	53737MA	1	RING, Quad
0321	583126MA	1	BEARING, Flange, 3/4 ID x 1-1/8 OD
0322	48275MA	1	WASHER, Thrust
0323	50684MA	1	BEARING, Roll Thrust, 3/4 ID x 1-1/4 OD
0324	48275MA	1	WASHER, Thrust
0326	50795MA	1	KEY, HI-PRO
0327	53732MA	1	WORMGEAR, 1-3/4 OD x 1-1/2"
0330	53731MA	1	BEARING, Sleeve, 3/4 ID x 7/8 OD
0340	1751535YP	1	SHAFT, Impeller
0380	1752515YP	1	RING, Retaining, 3/4

Footnotes

The above parts group applies to the following Mfg. Nos.:

1696411-00 - ST1074BS

Discharge Chute Group

2991260

NOTE: Unless noted otherwise,
use the standard hardware torque
specification chart.

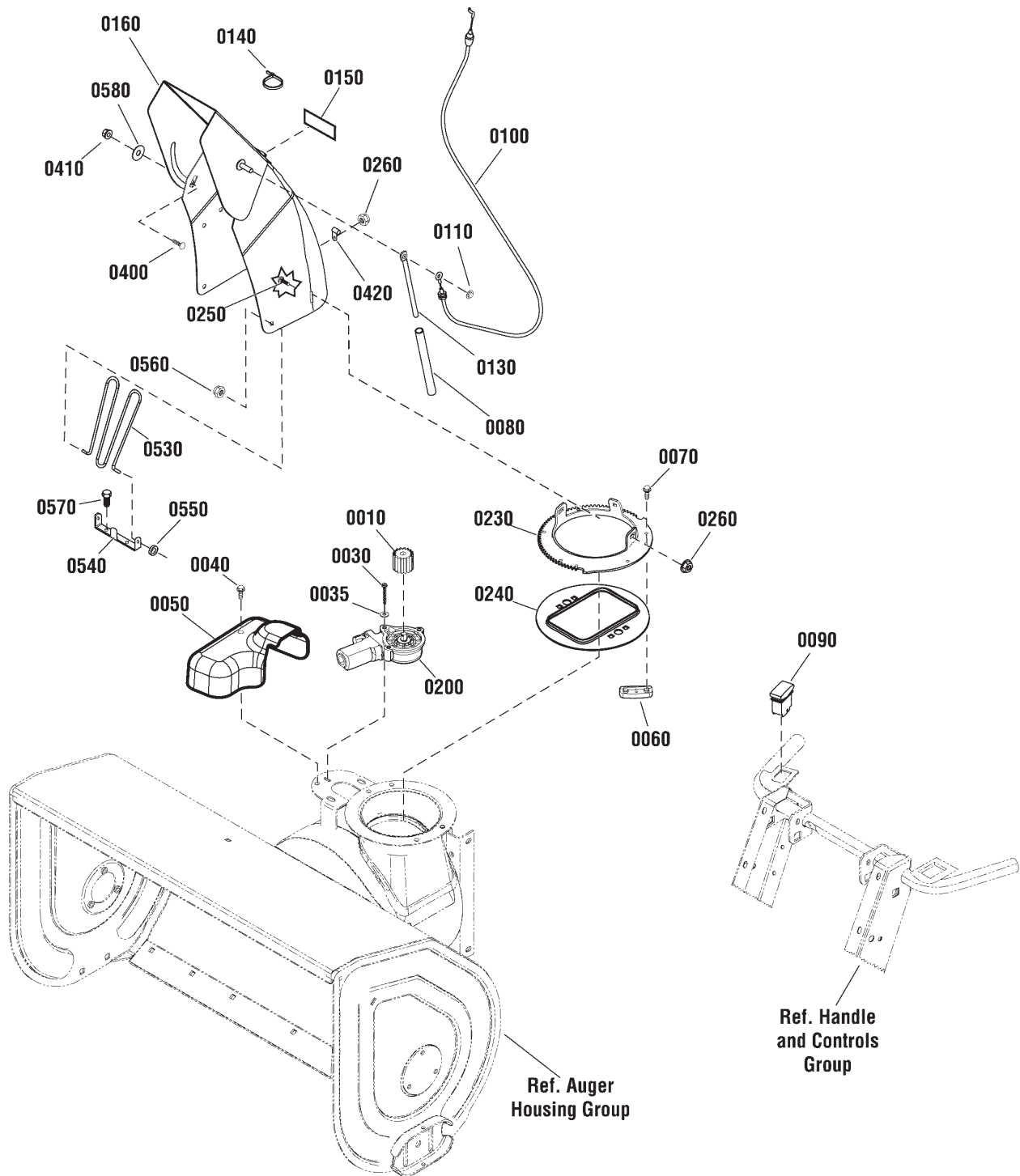

The above parts group applies to the following Mfg. Nos.:
1696411-00 - ST1074BS

Discharge Chute Group

REF NO	PART NO.	QTY.	DESCRIPTION
0010	1728967SM	1	PINION
0030	1739621YP	3	SCREW, Torx Button Head, M5 x .8 x 14
0035	7091552SM	3	WASHER, Flat, 7/32
0040	1925592SM	1	SCREW, Hex Washer Head, Taptite, 1/4-20 x 3/4
0050	1752877YP	1	COVER, Electric Chute Rotation
0060	7011938SM	3	RETAINER, Spout
0070	1960001SM	6	SCREW, Hex Washer Head, Plastite, 10-14 x 5/8
0080	1734647SM	1	SPRING, Compression
0090	1737378YP	1	SWITCH, Chute Rotation
0100	1750623YP	1	CABLE, Deflector Control
0110	1932718SM	1	PUSHNUT, 5/16
0130	1734708ASM	1	ROD, Spring Guide
0140	1701011SM	4	TIE, Self Lock
0150	1733601SM	2	DECAL, Strip for Chute Hinge
0160	1756705AYP	1	CHUTE
0200	1739309YP	1	MOTOR, Spout Rotator
0230	1737465AYP	1	GEAR, Chute
0240	1737411YP	1	ADAPTER, Chute Ring
0250	703101	4	BOLT, Carriage, 1/4-20 x 3/4, G5
0260	1960685SM	4	NUT, Hex KEPS, 1/4-20
0400	1931333SM	1	BOLT, Carriage, Short Neck, 5/16-18 x 3/4, G5
0410	1739305YP	1	NUT, Hex Flange, ESNA, 5/16-18
0420	1739331YP	1	CLIP, Cable
0530	1733475SM	1	GUARD, Chute
0540	1752883YP	1	BRACKET, Chute Guard
0550	1738174YP	2	GROMMET, Chute Guard Bracket
0560	1960140SM	2	PUSHNUT, 3/16
0570	1925003SM	2	SCREW, Hex Washer Head, Taptite, 1/4-20 x 1/2
0580	2860210SM	1	WASHER, Nylon

Footnotes

The above parts group applies to the following Mfg. Nos.:

1696411-00 - ST1074BS

Hardware Identification & Torque Specifications

Torque Specification Chart								
FOR STANDARD METRIC MACHINE HARDWARE (Tolerance ± 20%)								
Property Class	5.6		8.8		10.9		12.9	
	Class 5.6		Class 8.8		Class 10.9		Class 12.9	
Size Of Hardware	in/lbs		in/lbs		in/lbs		in/lbs	
	ft/lbs	Nm.	ft/lbs	Nm.	ft/lbs	Nm.	ft/lbs	Nm.
M3	5.88	.56	13.44	1.28	19.2	1.80	22.92	2.15
M4	13.44	1.28	30.72	2.90	43.44	4.10	52.56	4.95
M5	26.4	2.50	60.96	5.75	5.97	8.10	7.15	9.7
M6	44.64	4.3	7.3	9.9	10.3	14	12.1	16.5
M7	5.2	7.1	12.1	16.5	16.9	23	19.9	27
M8	7.7	10.5	17.7	24	25	34	29	40
M10	15	21	35	48	50	67	59	81
M12	26	36	61	83	86.2	117	103	140
M14	42	58	101	132	136	185	162	220
M16	64	88	147	200	210	285	250	340
M18	89	121	202	275	287	390	346	470
M20	126	171	290	390	405	550	486	660
M22	169	230	390	530	559	745	656	890
M24	217	295	497	375	708	960	840	1140
M27	320	435	733	995	1032	1400	1239	1680
M30	435	590	995	1350	1401	1900	1681	2280
M33	590	800	1349	1830	1902	2580	2278	3090
M36	759	1030	1740	2360	2441	3310	2935	3980
M39	988	1340	2249	3050	3163	4290	3798	5150

The guides and ruler furnished below are designed to help you select the appropriate hardware.

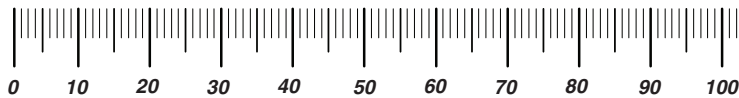

Nut, M8

Thread Diameter (mm)
Inside Diameter (in) Threads per inch

Nut, 1/2-16

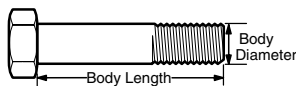

Screw, M8- 1.25 x 25

Thread Diameter (mm) Distance between threads (mm) Body Length (mm)
Body Diameter Threads per inch Body Length (in)

Screw, 1/2- 16 x 2

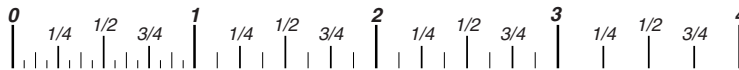

Standard Hardware Sizing

When a washer or nut is identified as **1/2"** (M8), this is the *Nominal size*, meaning the *inside diameter* is 1/2 inch (8mm metric thread diameter); if a second number is present it represents the *threads per inch* (distance between threads).

When bolt or capscrew is identified as **1/2 - 16 x 2"** (M8 - 1.25 x 50), this means the *Nominal size*, or body diameter is 1/2 inch (8mm metric thread diameter), the second number, 16, represents the *threads per inch*, (*1.25 thread diameter*). The final number is the body length of the bolt or screw, 2 inches (50mm).

Torque Specification Chart						
FOR STANDARD MACHINE HARDWARE (Tolerance ± 20%)						
Hardware Grade	No Marks		SAE Grade 5		SAE Grade 8	
	SAE Grade 2		SAE Grade 5		SAE Grade 8	
Size Of Hardware	in/lbs		in/lbs		in/lbs	
	ft/lbs	Nm.	ft/lbs	Nm.	ft/lbs	Nm.
8-32	19	2.1	30	3.4	41	4.6
8-36	20	2.3	31	3.5	43	4.9
10-24	27	3.1	43	4.9	60	6.8
10-32	31	3.5	49	5.5	68	7.7
1/4-20	66	7.6	8	10.9	12	16.3
1/4-28	76	8.6	10	13.6	14	19.0
5/16-18	11	15.0	17	23.1	25	34.0
5/16-24	12	16.3	19	25.8	29	34.0
3/8-16	20	27.2	30	40.8	45	61.2
3/8-24	23	31.3	35	47.6	50	68.0
7/16-14	30	40.8	50	68.0	70	95.2
7/16-20	35	47.6	55	74.8	80	108.8
1/2-13	50	68.0	75	102.0	110	149.6
1/2-20	55	74.8	90	122.4	120	163.2
9/16-12	65	88.4	110	149.6	150	204.0
9/16-18	75	102.0	120	163.2	170	231.2
5/8-11	90	122.4	150	204.0	220	299.2
5/8-18	100	136	180	244.8	240	326.4
3/4-10	160	217.6	260	353.6	386	525.0
3/4-16	180	244.8	300	408.0	420	571.2
7/8-9	140	190.4	400	544.0	600	816.0
7/8-14	155	210.8	440	598.4	660	897.6
1-8	220	299.2	580	788.8	900	1,244.0
1-12	240	326.4	640	870.4	1,000	1,360.0

NOTES

- These torque values are to be used for all hardware excluding: locknuts, self-tapping screws, thread forming screws, sheet metal screws and socket head setscrews.
- Recommended seating torque values for locknuts:
 - for prevailing torque locknuts - use 65% of grade 5 torques.
 - for flange whizlock nuts and screws - use 135% of grade 5 torques.
- Unless otherwise noted on assembly drawings, all torque values must meet this specification.

Common Hardware Types

Hex Head Capscrew



Washer



Lockwasher

Carriage Bolt



Hex Nut

Wrench & Fastener Size Guide

1/4" Bolt or Nut Wrench—7/16"	5/16" Bolt or Nut Wrench—1/2"	3/8" Bolt or Nut Wrench—9/16"	7/16" Bolt or Nut Wrench (Bolt)—5/8" Wrench (Nut)—11/16"	1/2" Bolt or Nut Wrench—3/4"
M6 Bolt or Nut Wrench—10mm	M8 Bolt or Nut Wrench—13mm	M10 Bolt or Nut Wrench—17mm	M12 Bolt or Nut Wrench—19mm	M14 Bolt or Nut Wrench—22mm

CHAMPION

**IT IS THE POLICY OF BRIGGS & STRATTON CORP. TO IMPROVE ITS PRODUCTS
WHENEVER IT IS POSSIBLE AND PRACTICAL TO DO SO. WE RESERVE THE RIGHT TO
MAKE CHANGES OR ADD IMPROVEMENTS AT ANY TIME WITHOUT INCURRING ANY
OBLIGATION TO MAKE SUCH CHANGES ON PRODUCTS.**

Briggs & Stratton Power Products Group

12301 W. Wirth Street
Wauwatosa, WI, 53222 USA

www.murray.com

© Copyright 2013 by Briggs & Stratton Corporation
Milwaukee, WI, USA. All rights reserved